

INSTRUCTION MANUAL

BGI 400

Personal Sampler Pump



**BGI Incorporated
58 Guinan Street
Waltham, MA 02451
Ph: 781-891-9380
Fax: 781-891-8151
<http://www.bgiusa.com>
e-mail: info@bgiusa.com**

BGI 400 Personal Air Sampling Pump

1.0 APPLICATION

To collect a sample of a contaminant from the air (preferably in the breathing zone). The choice of sampling head lies with the investigator. However, the BGI-400 was designed for use with the BGI/KTL cyclone which operates at 4 Lpm and provides a (PM) 2.5 size cut. Utilizing the KTL Cyclone fitted with a 37 mm cassette loaded with 0.8 μm MCE membrane, 24 hour samples is readily accomplished.

2.0 CONSTRUCTION

The aluminum case houses a double diaphragm pump, double pulsation dampners, electronic control board and an elapsed time indicator with a Lithium battery back up. External controls comprise an on/off switch, flow rate setting potentiometer and an access hole for resetting the elapsed time indicator.

The entire inside of the case is lined with sound deadening material which results in essentially silent operation.

3.0 SAMPLING

This instruction manual describes how the sampler works and how to maintain it. It does not detail how to sample, or how to analyze collected samples nor how to select methods for various investigations. The BGI instruction manuals for various sampling heads contain the information on their usage.

The battery must be fully charged to insure a 24 hour run. Full charging is achieved by connecting the battery to its charger and allowing a 16 hour period to elapse.

NOTE: The sampler should never be run without a filter on the inlet. A suitable filter is put into the appropriate holder and is connected by a length of plastic tube to the inlet of the sampler. Switch the pump ON using the slide switch located in the recess in the back of the case. A flashing light indicates that the pump is running. Setting of the flow rate is by adjustment of the potentiometer marked FLOW on the back of case. Turn clockwise to increase the flow rate.

In order to check the pump calibration prior to sampling, it is only necessary to connect a suitable rotameter (BGI Part No. RM67, 2-20 Lpm), a bubble meter or the BGI TetraCal (formally triCal) (BGI Part No. TC-5) to the filter inlet as shown in Figure 1. Adjust the FLOW screw to the desired sampling value, which will then remain constant within the specified limits of flow rate and pressure drop for any sampling head and filter. It is advisable to run the pump for 10 minutes before checking flow rate.

If it is desired to check the limits of pressure drop increase to which a filter can be utilized, then an optional valve and pressure gage should be inserted in the system. By closing the valve (and increasing the pressure drop), you are simulating an increasingly dirty filter. However, it should be emphasized that this is not a required procedure and is only presented as a matter of interest. When the flow rate has been set only routine checking is required as long as no change in flow rate is required.

For personal monitoring, attach sampling head in person's breathing zone. Do not neglect to reset the elapsed time indicator before sampling. This is accomplished by inserting a pin through the hole located near the display screen.

When sampling is to be ended, check flow rate, switch off and note time. The flow should be within +/- 5% of original setting. Put battery on charge using charger. To evaluate collected sample unload sampling head in the appropriate way, dispatch to laboratory with details of time, flow rate, location, probable contaminant, likely concentration and any other relevant points.

Check List Before Sampling

Make sure the battery has been fully charged. Insure sampling head is correctly fitted with no leaks. If flow rate cannot be obtained with similar conditions to previous occasions, suspect leakage.

Operational Run Time Limits

The BGI 4004, with 24 hour battery will run *more than* 24 hours against a resistance of 45 cm of H₂O at 4 Lpm. It will run *more than* 24 hours against a resistance of 40 cm of H₂O at 5.2 Lpm. Double those run times will be achieved with the 48 hour battery.

4.0 MAINTENANCE

Keep a record of hours used and replace parts at intervals:

Part	Replacement Interval in
Hours	
Valves	2000
Pump diaphragm	2500
Dampner	2500
Ball Bearing on eccentric	4000
Motor	4500

NOTE: If above maintenance is carried out, failure to obtain a sample should be very infrequent. If conditions of use are in dusty surroundings or are in rough handling locations, replacement intervals may be shorter.

4.1 SERVICING

It is highly recommended that repairs and service are carried out at BGI, by trained personnel. Nevertheless, it is recognized that there may be reasons or need for user performed servicing.

4.1.1 PUMP UNIT - FIGURE 2

1. Remove the four screws, remove case lid shown in Figure 2.
2. Lift out the pump unit together with the circuit board to avoid straining the motor connection to board.

4.1.2 VALVES - FIGURE 3

1. Remove the double valve chest. Note position and method of securing valves and discard.
2. Examine valve seat C. Use non-metallic probe- for example, wooden toothpick to remove dirt. Use care at valve edge.
3. Fit new valves.

Replace valve chest. Do not use too much pressure when tightening screws.

4. Brush any dust from the ball bearing in eccentric. Put one drop of lubricant on motor bearing.

4.1.3 PUMP DIAPHRAGM FIGURE 3

Diaphragm should be replaced at the recommended interval or if the slightest damage is suspected. First follow the steps in section 4.1.2 and 4.1.3 but do not reassemble.

A. Withdraw the screw, now visible in the center of the support disk. Withdraw the diaphragm and both support disks. Note direction of convolution in diaphragm and replace new diaphragm in the same direction.

B. Reassemble in reverse order and attend to the opposite side of the pump.

4.1.4 MOTOR AND BEARINGS

It is not recommended that the replacement of the bearings on the eccentric shaft be attempted. The bearings and eccentric are available as a complete assembly.

A. Remove valve chests, clamp rings and diaphragm as above.

B. Loosen set (Grub) screw and withdraw eccentric and bearings as a complete assembly.

C. Remove three screws holding motor in place and withdraw motor from chassis.

D. Carefully unsolder electrical leads from old motor and transfer to new motor.

E. Reassemble in reverse order.

4.1.5 ELECTRONIC CONTROL CIRCUIT - FIGURE 4

If the pump does not run carry out the following checks

A. That battery voltage appears at the input terminals of the control board.

B. That a voltage appears at the motor terminals.

If no volts at input, check battery and connections.

If no volts at the motor terminal, the control board should be replaced.

4.1.6 SETTING THE CONSTANT FLOW COMPENSATION CIRCUIT - FIGURE 5

As the pump unit is received from the factory, the circuit is properly set up for 4 Lpm. The following information is presented for checking purposes or when other than factory repairs have been effected.

NOTE: The pump is set to give the minimum variation in flow rate against a pressure drop at 4 Lpm. And at this setting there will be very little change in flow rate. It may be necessary to make minor adjustments to the trimmer potentiometer, VR2, Figure 4, to obtain the $\pm 5\%$ accuracy at 4 Lpm. For greater accuracy at any flow rate within the range, this procedure should be followed using the required flow rate at the datum.

Referring to Figure 5, set the shut off and load valve fully open. Adjust the FLOW potentiometer (VR1) to the desired flowrate (say 4 Lpm) and allow one minute to stabilize. Close the shut off valve and close down the load valve until a pressure drop of approximately 15 inches H₂O back pressure is achieved. If necessary, adjust the potentiometer VR2 to bring the flow back to the desired figure (in this case 4 Lpm). Open the shut off valve. If the flow has altered from the set point (4 Lpm), reset with potentiometer VR1 (FLOW) and repeat the above procedure.

4.1.7 DAMPNERS - FIGURE 2

The Dampners are a glued up assembly and are not user repairable. The complete dampner assembly may be returned to the factory for rebuilding or a complete new assembly acquired.

4.1.8 BATTERY CHARGE

This component has an extremely long life and is not a servicable item. If inoperative, replace.

NOTE: If, after replacement of a part, performance is not regained it is usually an indication some procedure has not been carried out correctly or that there is a small leak. Most common cause of poor performance is in the valve. They must be flat and aligned on valve seat.

5.0 ALTERATIONS WITHOUT NOTICE

The contents of this manual are subject to alteration without notice. As specifications and design of instruments are under continual review, illustrations and descriptions should not be taken as correct in every detail.

6.0 FAULT TRACING

Your personal sampler is designed and engineered for long distance and dependable service but as a precision instrument it should be given the best of care.

Typical problems are shown on the accompanying chart. When testing, refer to the exploded views contained in this manual.

Other than service hints outlined in the instruction manual, we recommend factory service by technicians trained and equipped to repair your sampler. Should you wish factory repair assistance obtain an RMA from our website (www.bgiusa.com), pack your sampler in a carton equal to the original packaging. Insure to full value and ship prepaid. Include a letter giving full details with your packing list.

SYMPTOM	POSSIBLE CAUSE	SERVICE HINT
Pump does not run	Battery fully discharged	Replace with fully charged battery
LED not illuminated	Wiring loom disconnect at some point	Locate and resolder joint
	Fault on circuit board	Replace
Pump does not run LED illuminated	Eccentric bearing seizure	Replace
	Motor shaft seizure	Replace motor
Motor runs but pump inoperative	Set screw securing eccentric to motor shaft loose	Retighten
Pump runs but no air drawn	Diaphragm rubber split	Replace
	Pulsation dampner membrane split	Renew pulsation dampner

	Flow potentiometer on bottom setting	Readjust
	Tube between pulsation dampner and valve chest split or disconnected	Replace
Pump runs but cannot achieve flowrate	Leak on pump assembly	Locate and correct
	Dirt under valves or valves damaged	Replace
	Flow potentiometer inoperative	Replace circuit board
Cannot obtain full cycle working even when pressure drop does not exceed 15 ins H ₂ O	Incomplete charge	Recharge
	Battery below capacity	Fully charge
	End of battery service life	Replace battery
	High current consumption due to mechanical defect in pump	Locate and correct

7.0 BGI-400 PARTS LIST

BGI PART #	DESCRIPTION	QUANTITY	FIGURE
400A	Pump Motor Assembly 3-6 Lpm	1	2
DA1	Dampner Assembly	1	2
TPCB400	Timer Board	1	2
PPCB400	Pump Board	1	2
HS-02	Connector Tubes	2	2
HS-01	Connector Tube	1	2
SW52	On/Off switch	1	2
7576/A28	Belt Clip	1	2
A1793	Belt Clip Spacer	1	2
A2005	Inlet Tube	1	2
BNC1	Electric Connector	1	2
B-01	LED	1	2
SPC-01	TPCB400 Spacers	2	2
SC-01	TCPB400 Screws	2	2
NUM-161	TCPB400 Nuts	2	2
SM912-8	Switch Screws	2	2
NUM160	Switch Nuts	2	2
SC-03	Belt Clip Screws	2	2
SC-02	PCB Holder Screws	4	2
NUM162	Belt Clip Nuts	2	2
A1792	PCB Holder	1	2
A2125	Valve Chest	2	3
A1956	Valve	2	3
A1955	Valve Seat	2	3
10057	Diaphragm	2	3
7806-1A10	Diaphragm Support Disk	4	3

A1630	Yoke	1	3
-------	------	---	---

BGI PART #	DESCRIPTION	QUANTITY	FIGURE
MO-50	Motor	1	3
A1496/2	Eccentric/Bearing Assembly 3-6 Lpm	1	3
HK-2	Eccentric Set Screw	1	3
SM1824-8	Motor Mount Screws	3	3
400-1A	Diaphragm Screws	2	3
SM2130-8	Valve Seat Screws	8	3
SM1736-8	Valve Chest Screws	12	3
A1946	Pump Body	1	3

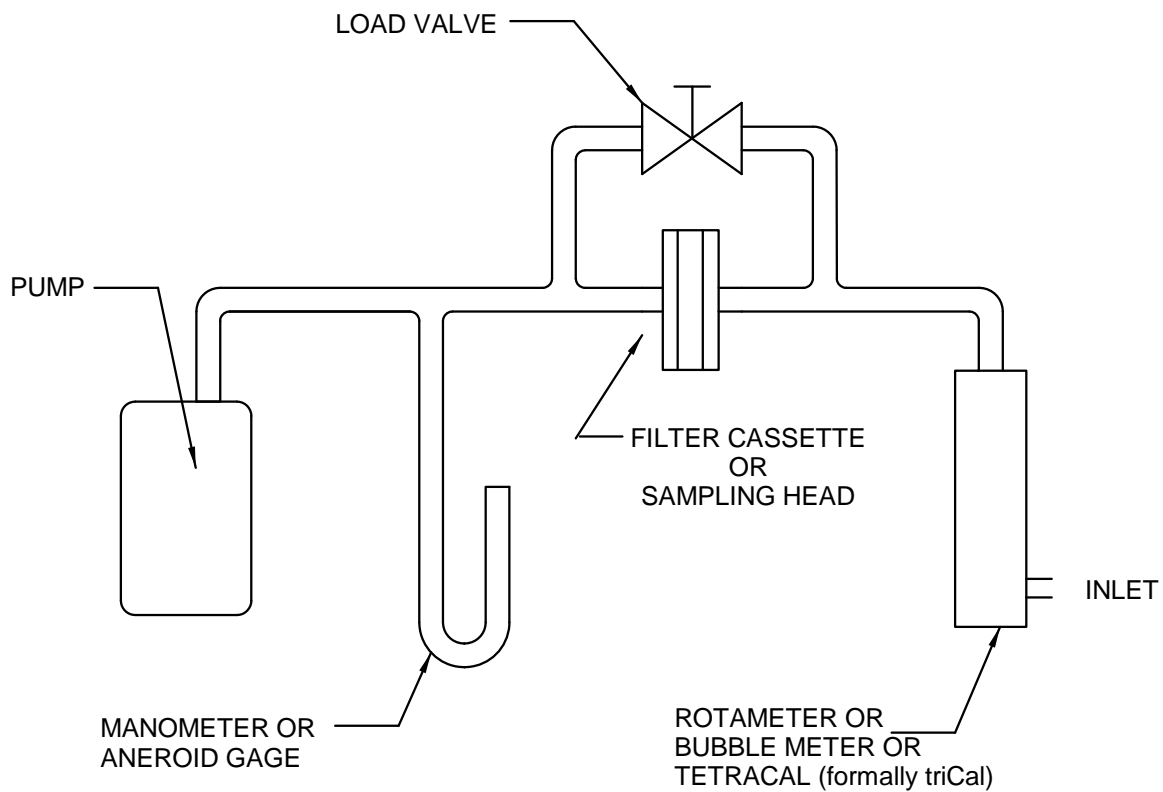
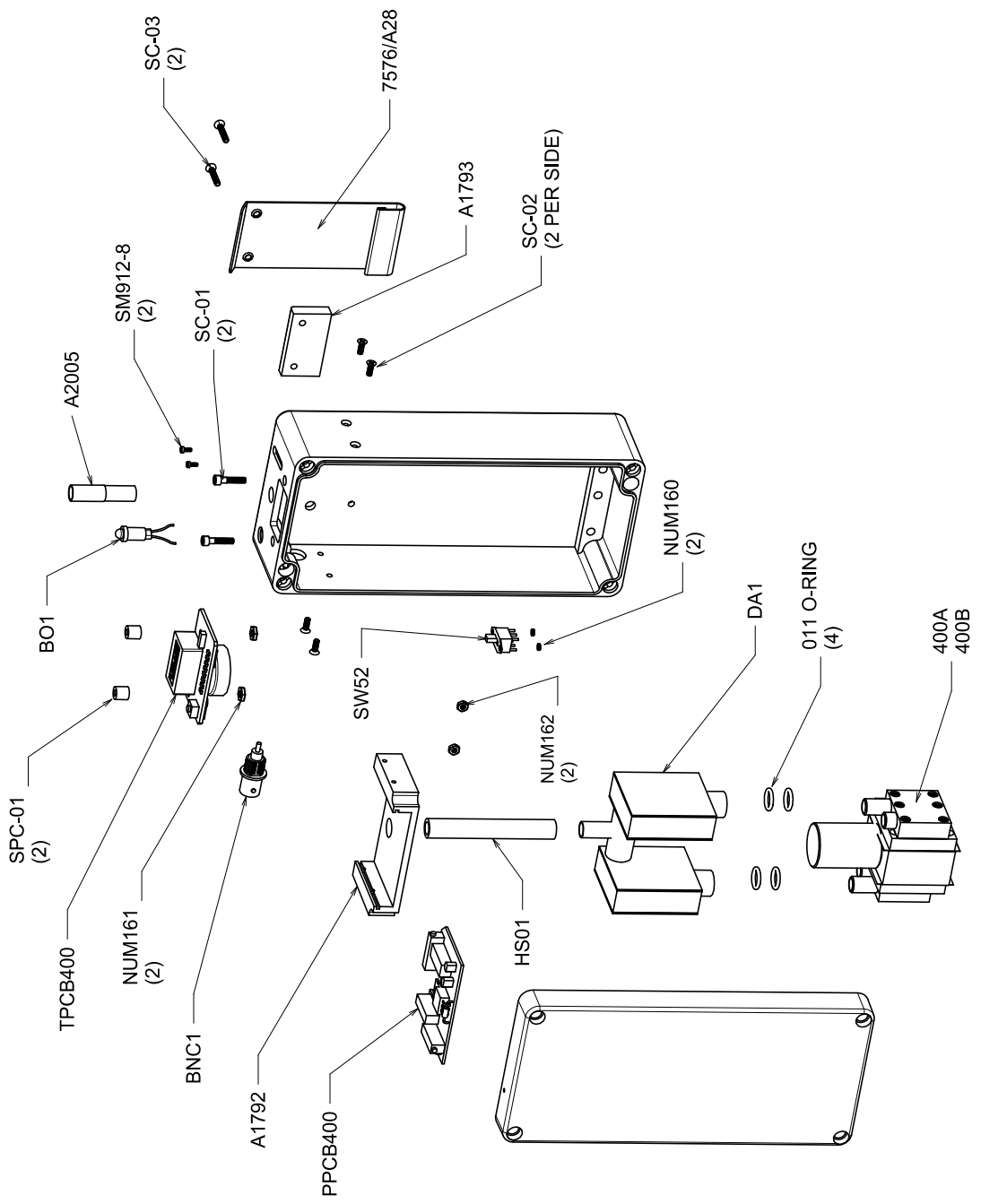

Figure 1: Schematic of Flow Setting and Testing Circuit

2016



2018

Figure 2: BGI 400 (Only numbered components available for replacement)

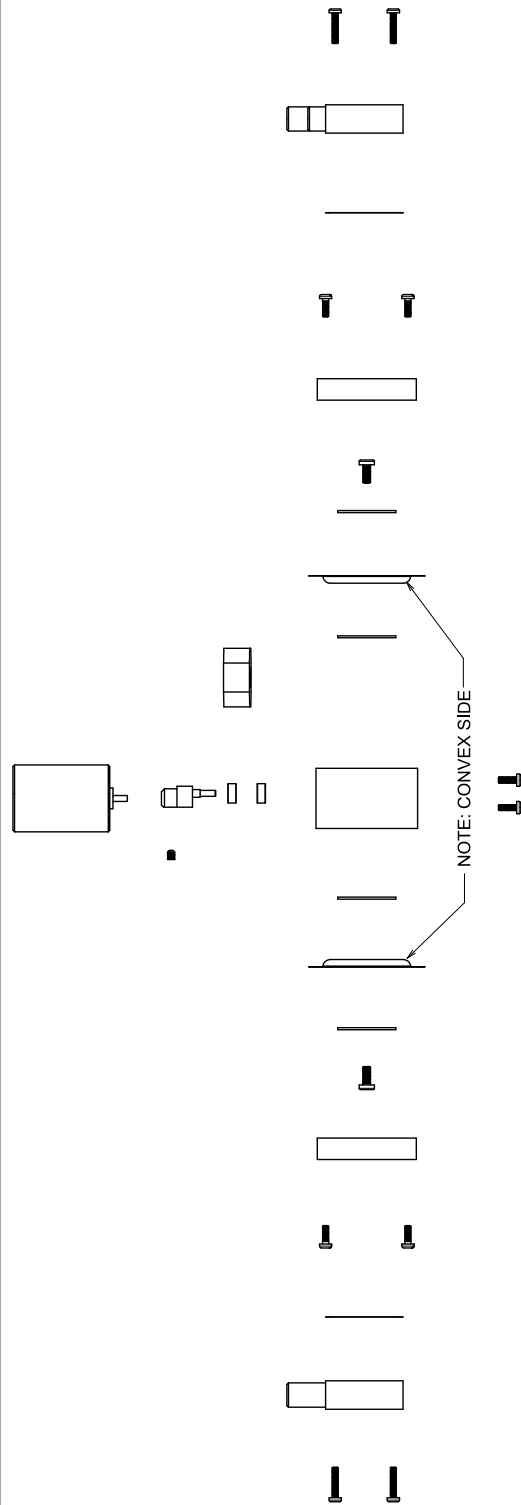
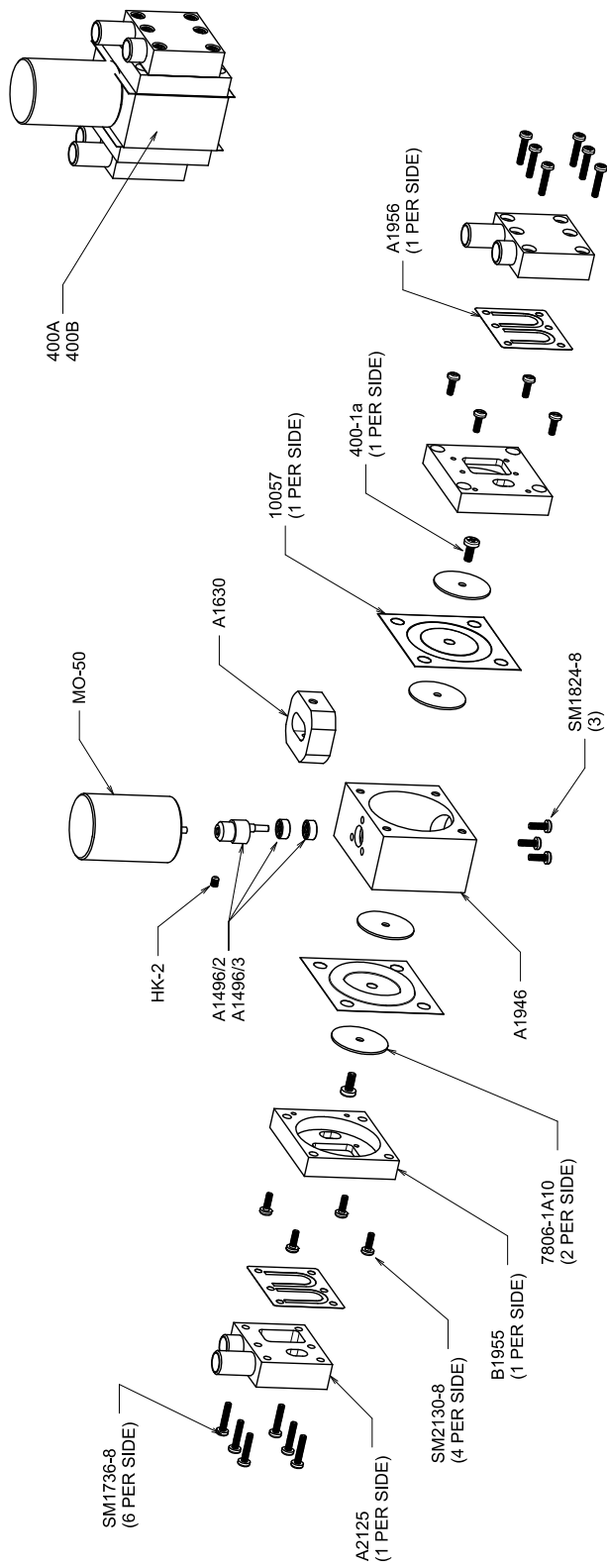

2019
 Figure 3: Pump Assembly. (Only numbered components available for replacement)

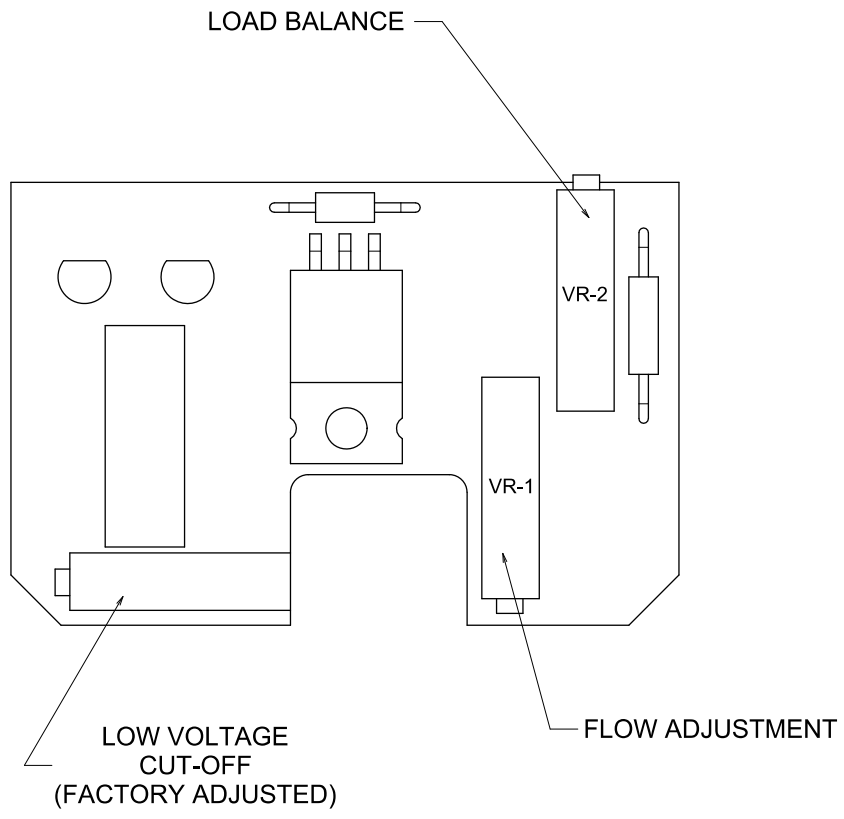

2017

Figure 4: PCB

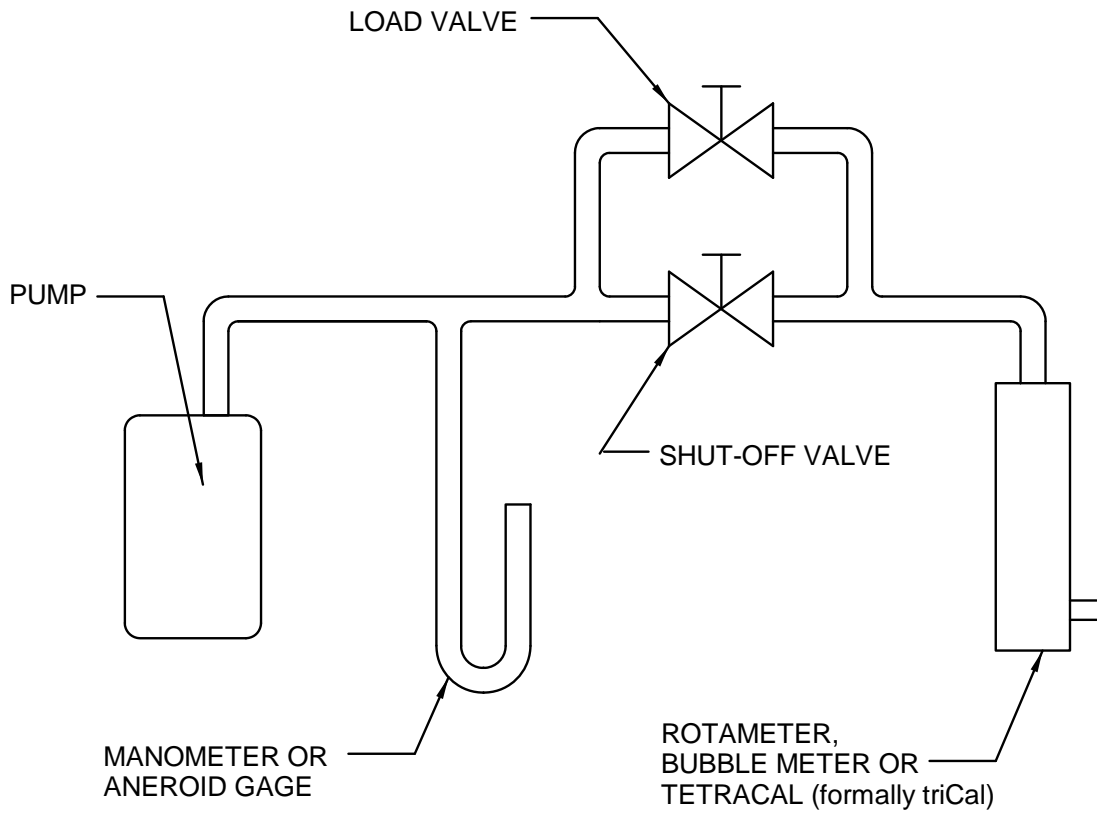

Figure 5: Schematic of Apparatus for Testing and Setting Electronic Flow Regulation Circuit.

2015

Revision History

Version 1.0	Manual Published	February 1999
Version 1.1	Corrections, additions	February 2002
Version 1.2	Added "TetraCal"	May 2007
Version 1.3	Removed obsolete items	September 2009
Version 1.4	Updated Fig. 2, 3 & 4	February 2010