

# *tetraCal*<sup>TM</sup> - ULTRA

**Laboratory/Field Audit Calibrator**

***NIST Traceable – ISO 9001:2008***

**1 TO 60 Lpm**

BGI Incorporated  
58 Guinan Street  
Waltham, MA 02451  
Tel: 781.891.9380  
Fax: 781.891.8151  
[www.bgiusa.com](http://www.bgiusa.com)  
[email: info@bgiusa.com](mailto:info@bgiusa.com)

## Table of Contents.

<b>Section</b>	<b>Topic</b>	<b>Page</b>
1.0	Quick Start	3
2.0	Introduction	3
3.0	Specifications	6
4.0	Principle of Operation	11
5.0	Instrument Set Up	11
6.0	Using the Calibrator	13
7.0	Software	15
8.0	Maintenance	15
9.0	Safety	15
10.0	Warranty	16
Appendix A	NIST Traceability	16
Appendix B	Lubrication	19

## 1.0 Quick Start

In order to put the instrument to immediate use as a Calibration/Audit device, follow these steps.

Step 1: Remove the instrument from its carrying case and turn it on.

Step 2: Install the correct venturi for the flow rate range of interest ("O" rings visible).

#1 20-60 Lpm

#2 6-20 Lpm

#3 1-6 Lpm

Step 3: Install a tubing adapter of the appropriate diameter onto the venturi and connect it to the instrument being audited/calibrated with, user supplied, elastomeric tubing.

Step 4: With air flowing, you may now read the screen to determine volumetric flow rate, standard flow rate, ambient temperature and barometric pressure.

For a diagram of the immediate application refer to Figure 1.

## 2.0 Introduction

All BGI calibrators are based on the air flow measurement principle of the venturi<sup>1</sup>. Our calibrators are developed by BGI and are manufactured in BGI's ISO 9001:2008 facility. The instruments provide an LCD indication of *volumetric* flow rate, *standard* flow rate, barometric pressure and ambient temperature. It operates on *either* four AA alkaline energy cells (batteries) or a (provided) line (mains) power module. The electronics are all housed in the control module.

The instrument is furnished with three auto ranging Venturi, which covers the flow rate range of 1 to 60 Lpm.

There are two ways that practitioners of air sampling measure and talk about flow rate.

Those doing compliance sampling for Industrial Hygiene/Occupational Health speak of **Volumetric** or **Actual** Air Flow rates. It is the volume of air at the existing pressure and temperature at the sampling site. The US EPA also specifies this type of measurement for PM<sub>2.5</sub>. *Electronic* meters of the bubble, piston, Venturi and orifice type "read out" in volumetric flow rate or **Q<sub>A</sub>**. There are exceptions which do both.

EPA, for Politico Legal, reasons uses **Q<sub>S</sub>** known as **Standard** Air flow rate for reporting PM<sub>10</sub>. This means that the flow rate is reported to **Standard** conditions. For the US EPA, these conditions are 25 C and 1 atmosphere pressure. (1 Atmosphere = 760 mm of Hg = 29.92 in of Hg = 1013.25 millibars = 1013.25 hecto Pascals).

Because the mass of air flowing could be calculated from Q<sub>S</sub> it has come to be called **Mass flow**. Throughout most of the world Q<sub>S</sub> is not usually referred to as mass flow and it is to a different standard. The conditions outside of the U.S. are 0 C and 1013.25 mb.

Volumetric devices are in the majority and any of them may be used to measure Q<sub>S</sub> if there is also knowledge of the T and BP, in the immediate locale, either from the instrument itself or supplemental instruments.

$$Q_S = Q_a * (BP_a/760)*(298.15/T_a+273.15) \text{ For U.S. applications when } T_s=25 \text{ C and } BP_s=760 \text{ mm of Hg}$$

$$Q_S = Q_a * (BP_a/1013.25)*(273.15/T_a) \text{ For world applications when } T_s=0 \text{ C and } BP_s=1013.25 \text{ mb}$$

Inasmuch as the tetraCal-Ultra generates Qa, Ta and BP information on a continuous basis it was decided in mid 2006 to implement new code which would provide both **Qa** and **Qs** information. At the same time, the two most popular Barometric pressure units (mm of Hg and millibars or hecto Pascals) are also provided. This results in two new screens;

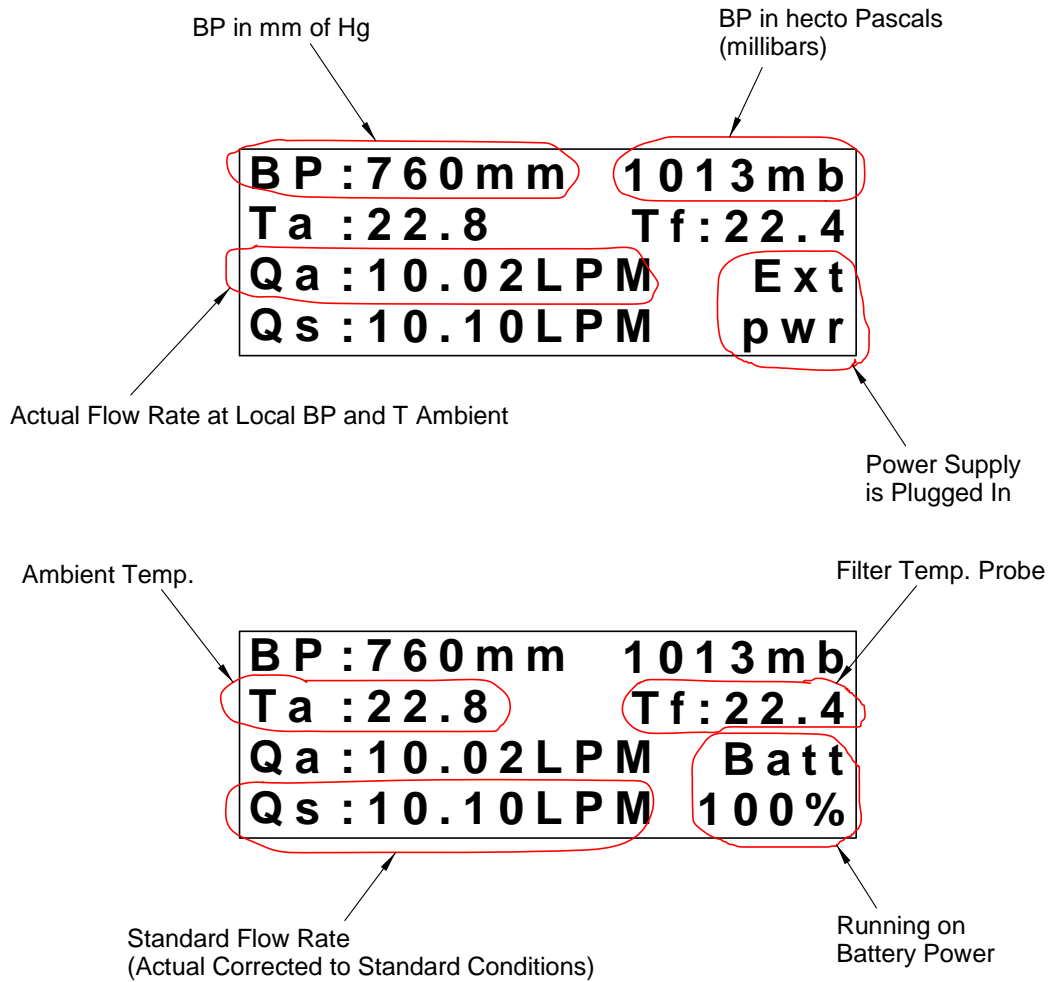

3041

*Remember*, Qs is always set to sea level conditions, but the Standard temperature is always factory set to either **25 C** (US EPA, Canada and other countries using US EPA conditions) or **0 C**. If the Firmware version contains the letter **W** (for world) the temperature base is **0 C**.

The new ambient temperature measuring device is a Gill Screen. It is to be found on all manner of environmental instruments including those Designated by the U.S. EPA. Its function is to get the ambient temperature sensor out of the housing where it may become falsely heated by electrical

components. It also protects the sensor from solar heating. The slightest of breezes will bring the sensor to the correct ambient temperature in about a minute. The configuration of the Screen equipped instrument is readily recognized as shown in Figure 1 . Figure 2 illustrates the layout of the travel case. Figure 3 shows the internal flow path of the tetraCal-Ultra, schematically detailed in Figure 4. Figure 5 illustrates the complete tetraCal-Ultra assembly.

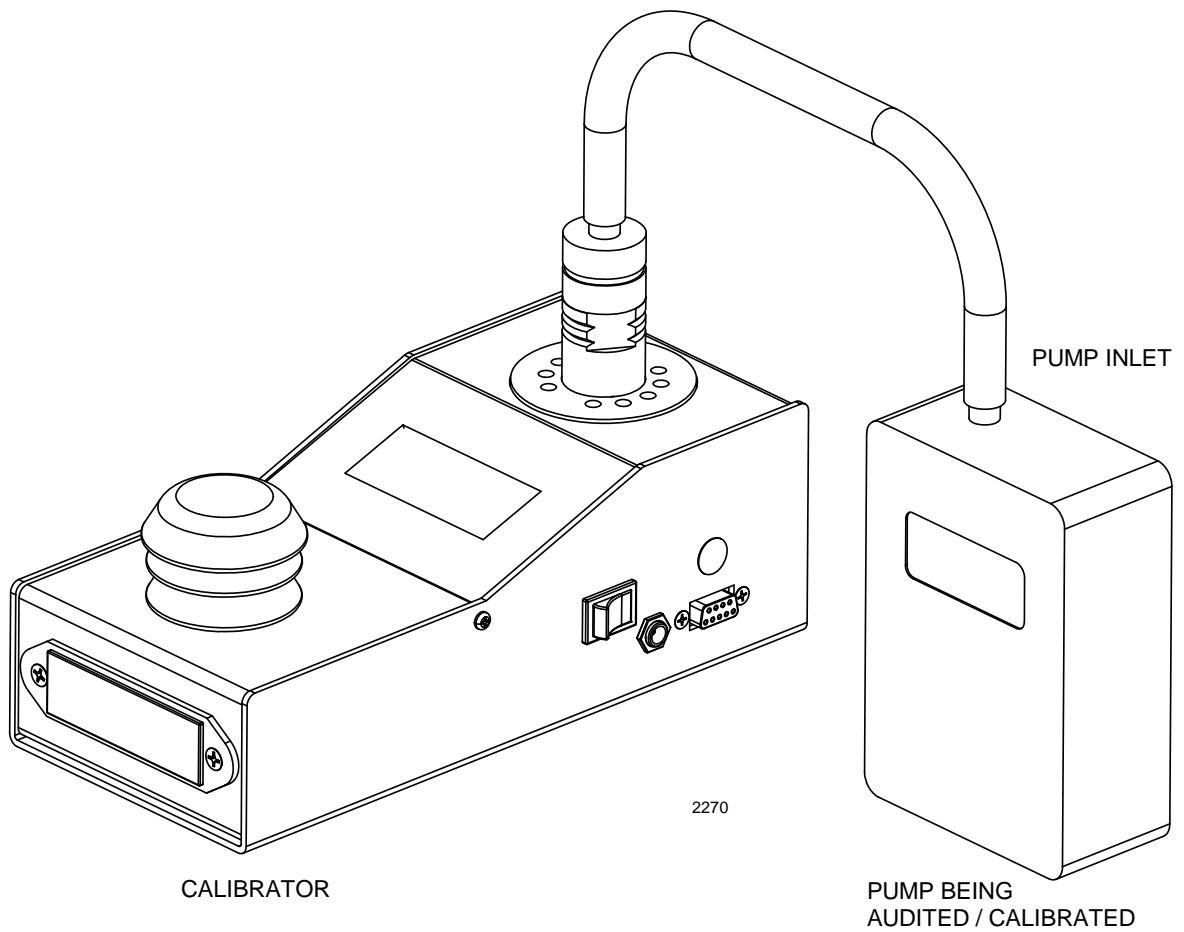

Figure 1 – “Quick Start” Application of Calibrator

### 3.0 Specifications

Flow rate range: 1 – 60 Lpm ( $\pm 1\%$ )  
 Temp. operational range -30° C to 55° C  
 Temp. reading range -30° C to 55° C ( $\pm .5^\circ$  C)  
 Barometric pressure range 400 to 800 mm of Hg ( $\pm 5$ mm)

Dimensions:

Control Module: 3.25 in. high ( 8.25 cm) X 3.125 in. wide ( 7.94 cm) X 9 in. long ( 22.86 cm)  
 Height with venturi and hose adaptor 6.30 in. (16.00 cm)

Weight w/ 1 venturi 2.38 lbs (1.08 kg)

Carrying case:

Dimensions: 15.75 in wide (40.00 cm) 4.5 in high (11.43 cm)  
 12.25 in. thick (31.20 cm)

Weight complete with contents 4.69 lbs (2.13 kg)

One complete instrument comprises:

Quantity	Description	Catalog/Part No.
1	calibrator	TC-14
1	Plug in Power Supply	DC-3 (120/240V)
4	Extra AA batteries	replacements obtained locally by user
1	Instruction Manual	Download PDF file from BGI website
1	Fitted Carrying Case	TC-6
1	Software Disk	TC-7
1	Venturi No. 1	TC-V4
1	Venturi No. 2	TC-V1
1	Venturi No. 3	TC-V2
1	¼ in. hose adapter	TC-H1
1	3/8 in. hose adapter	TC-H2
1	1/2 in. hose adapter	TC-H3

The calibrator, in its carrying case is shown in figure 2

Replacement supplies (not included with initial purchase).

1 Pkg. of 6	Replacement hose adaptor "O" rings	016 Silicone
1 Pkg. of 4	Replacement venturi socket "O" rings	022 Silicone

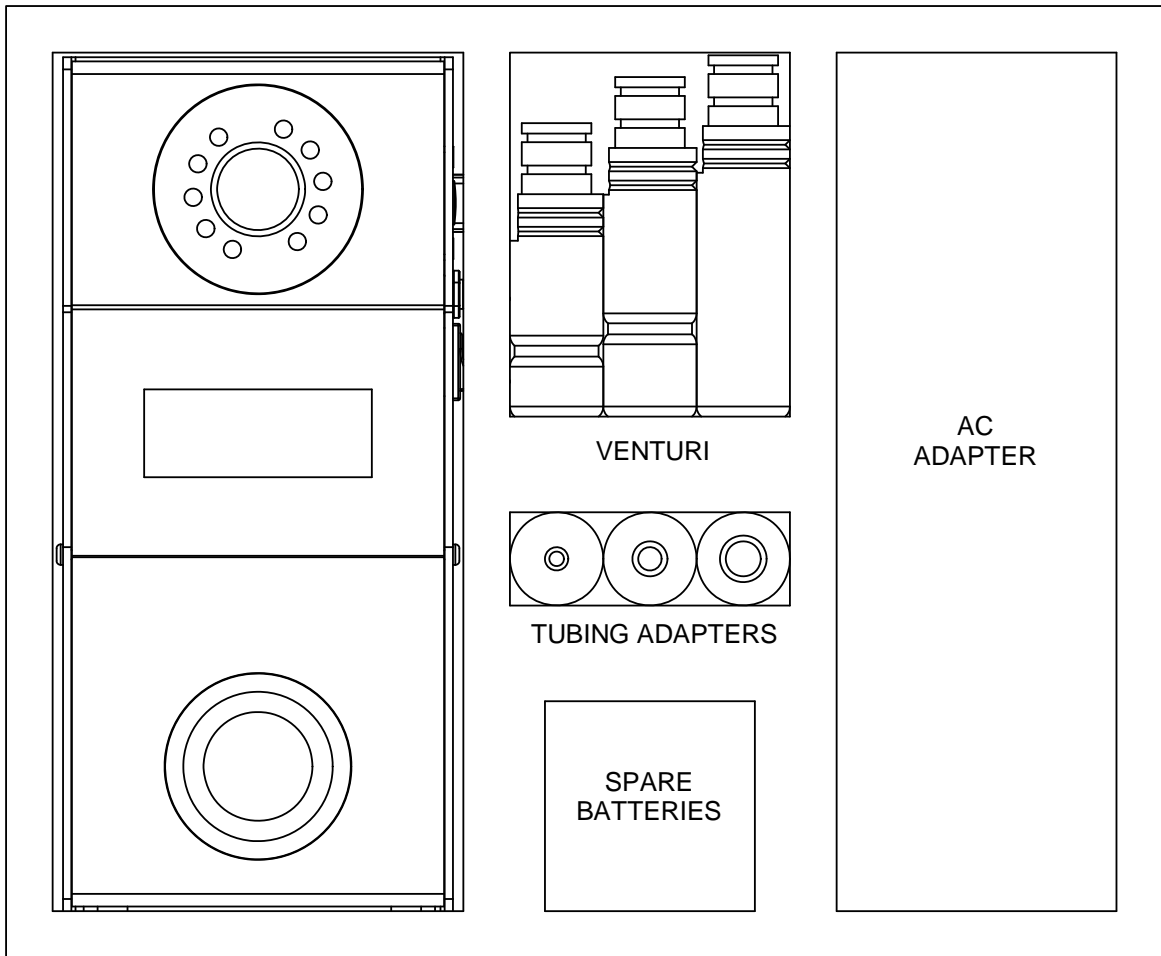

3043

Figure 2 – tetraCal Ultra in Travel case

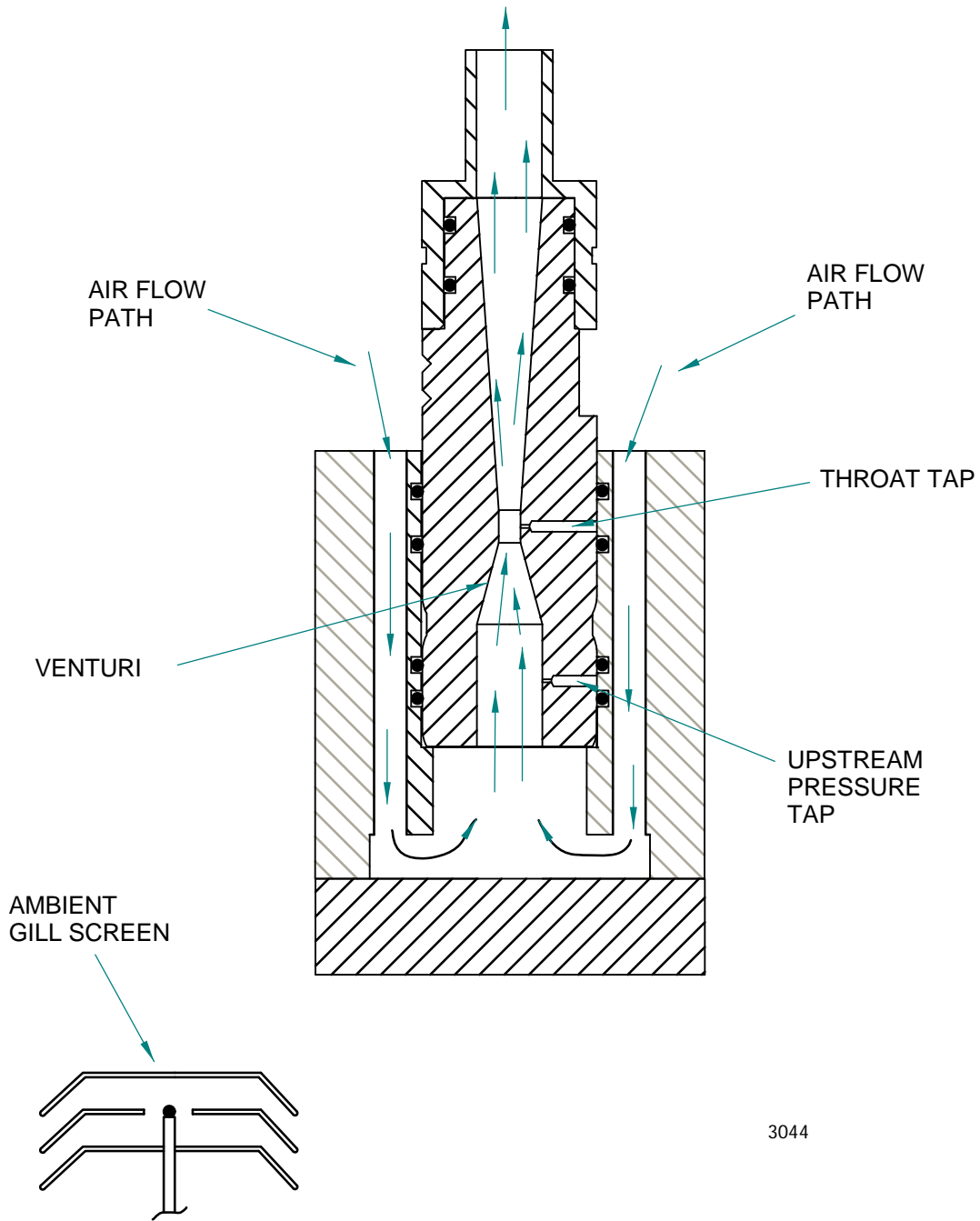

3044

Figure 3 – Sectional View of Measuring Section

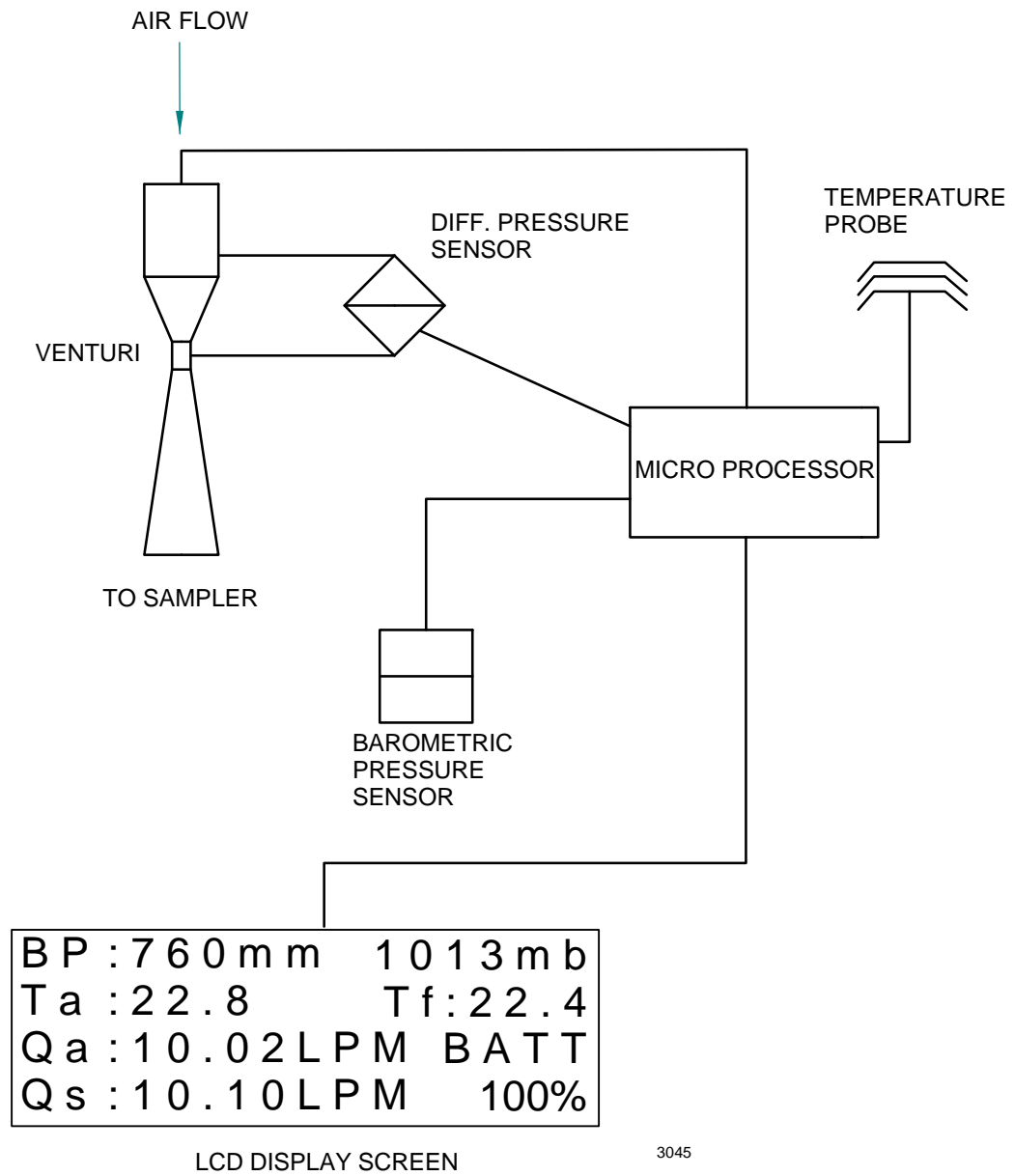

Figure 4 – Schematic Diagram of tetraCal Ultra

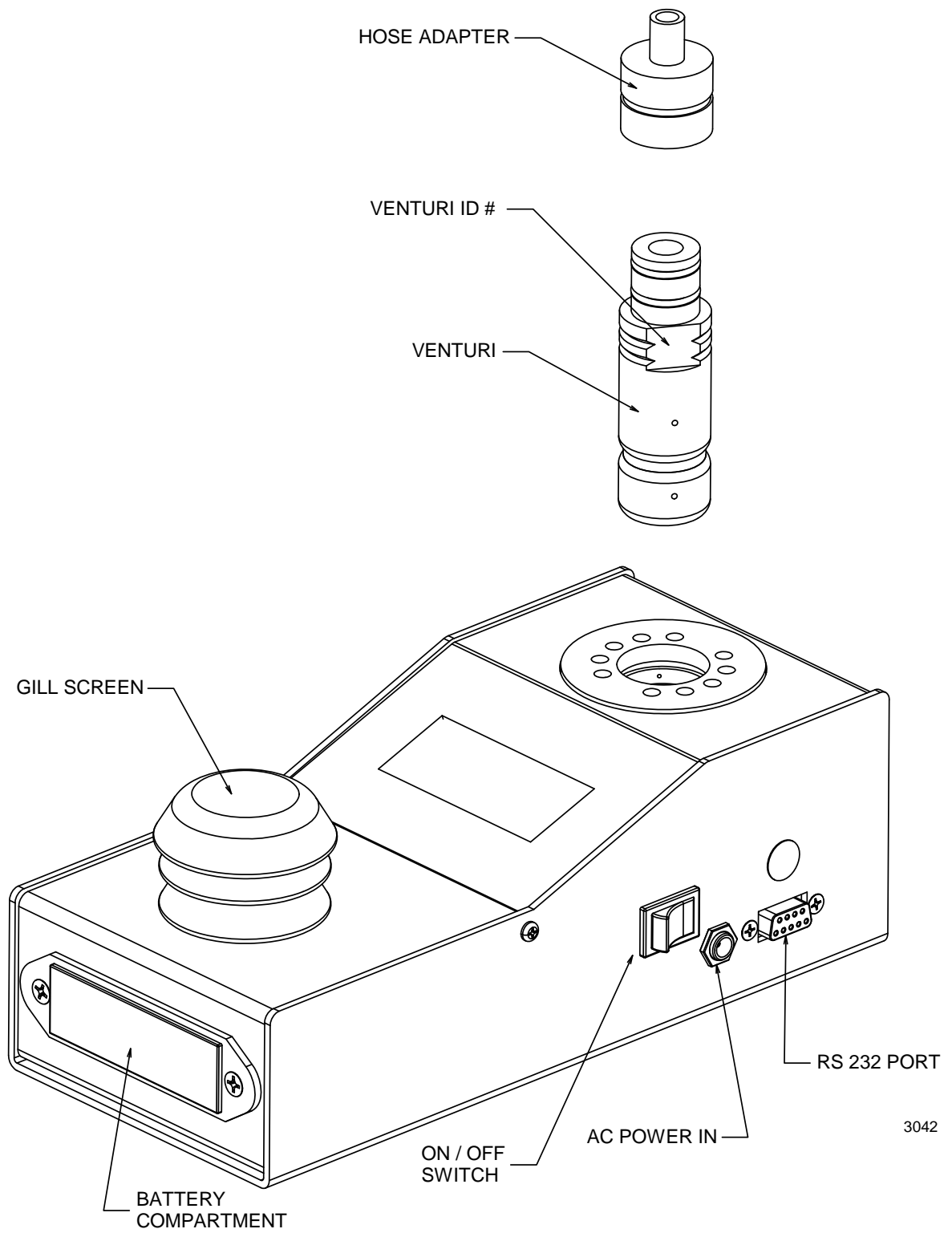

Figure 5 – tetraCal Ultra Assembly

## 4.0 Principle of Operation

The calibrator measures volumetric flow rate by utilizing a pressure transducer to assess the pressure drop caused by air being drawn through a venturi. As the flow rate through the venturi increases, the pressure drop increases as the square root<sup>1</sup>. A four times increase in pressure drop yields twice the flow rate. A desirable feature of the venturi is that most of the pressure drop created by the instrument is recovered in the expansion section of the venturi. Therefore, measurements are made at nearly the true operating conditions of the sampler.

The signal from the pressure transducer is sent to the microprocessor where, it is combined, via an algorithm with information from the barometric pressure sensor and the ambient temperature sensor. To eliminate "fluttering" of the on screen display, of volumetric flow rate, the first 20 readings are averaged and then carried on as a rolling average. Barometric pressure and temperature are monitored and displayed on a continuous basis, when the instrument is switched on. A cutaway diagram of the measuring head is shown in figure 3 and a schematic diagram of the system is shown in Figure 4.

## 5.0 Instrument Set-up

Remove the instrument from its carrying case. The only control is an off/on switch on the right side. If the instrument is to be used in the laboratory, plug the power supply into a power source (mains), otherwise it will operate from its internal batteries (4 AA Alkaline cells). Switch the instrument on and the screen will display the following message:

**Please insert  
Venturi 1-2-3**

Select a Venturi for the flow range of interest. Each venturi is marked with a number indicating the range:

1=20-60 Lpm  
2=6-20 Lpm  
3=1-6 Lpm

With the venturi held vertically, plain end downwards ("O" rings up), plunge the venturi into the hole in the top of the socket. Be certain that there is sufficient lubricant on the "O" rings within the recess. (See appendix 3 about lubrication). Select a cap for the venturi of an appropriate size to match the tubing being utilized to connect to the sampling device under test. Again, be certain that the "O" rings are lubricated. At this point the instrument will automatically reboot and autorange to the selected venturi. The screen will now appear as follows:

**BP: XXX mm    XXXXmb  
Ta. XX.X C    Tf. XX.X C  
Qa : Under range  
Qa : Under range**

Using a short length of elastomeric tubing, connect the sampler under test to the top of the Venturi and turn it on. The volumetric and Standard flow rate will now appear on the screen (See Figure 4).

### **Important points to be noted concerning the utilization of the calibrator**

- A. The venturi must have no air flowing through it.

*Every time the instrument is switched on, it re-zeros itself. If air is flowing, that flow rate will be set as zero.*

- B. The control module must be flat on the table, when switching on. The case houses the pressure transducers, which are subject to the force of gravity. Positional changes can give rise to minor errors. This effect applies to all devices containing pressure transducers.
- C. In order to perform the most precise measurement audit, it is necessary for the device to be in thermal equilibrium with the ambient environment in which the sampler to be tested is located. The best procedure is to deploy the calibrator, out of its carrying case, for one hour prior to the test, in the vicinity of the sampler to be audited. With the introduction of anodized Aluminum components during 2004 this time constraint is reduced to 10 minutes. Additionally, *if the calibrator is subject to a temperature change of more than five degrees, during use, it should be rebooted.*

When the calibrator is switched on and no external power is being utilized XX % battery capacity remaining is displayed on the screen. So long as more than 10% is indicated, it is safe to proceed, in that, at least one hour of power is available. If the provided AC adaptor is utilized, the screen will indicate "DC In" and there is no limit to the run time.

Note; Use of an AC power supply, other than the one provided, can cause severe damage to circuit components. If the unit provided becomes lost or dysfunctional, use only AA batteries for operation.

The test is now ready to be performed.

## 6.0 Using the calibrator

### 6.1 To perform an audit

*One* of two procedures should now be performed.

Procedure A. Turn *off* the sampler to be audited. Connect the calibrator to the inlet to the sampler with, user provided tubing. Turn *on* the calibrator, wait for the screen to finish the startup boot, *then* turn on the air sampler.

Procedure B. With the sampler to be audited *running*, when the calibrator I screen has finished its startup boot, connect the measuring tube to the instrument under test

The flow resistance of the calibrator I may cause momentary instability in the air samplers flow control circuit. Once the air samplers flow rate indicator stabilizes, the reading may be taken. A simple audit data format suitable for EPA type samplers is shown in Table 1. This may be taken as a guide to formulating a form suitable for your specific needs.

### 6.2 To perform a calibration.

The procedures and calculations for using the instrument to calibrate a sampler are the same as an audit, *except* that one should set the sampler to the exact flow rate required.

### Table 1 Audit Data Format

Audited Instrument:

Make: \_\_\_\_\_ Model: \_\_\_\_\_ S/N: \_\_\_\_\_

Date: \_\_\_\_\_ Time: \_\_\_\_\_ TCal S/N: \_\_\_\_\_

---

Flow Rate – Lpm

Sampler: \_\_\_\_\_

% diff. = [(TCal-sampler)/TCal]x100

TCal: \_\_\_\_\_

Allowed diff. = 4%; Pass \_\_\_\_\_ Fail \_\_\_\_\_

---

Ambient Temp. – C

Sampler: \_\_\_\_\_

TCal: \_\_\_\_\_

Allowed diff. = ± 2 C; Pass \_\_\_\_\_ Fail \_\_\_\_\_

---

Barometric Pressure – mm of Hg

Sampler: \_\_\_\_\_

TCal: \_\_\_\_\_

Allowed diff. = ± 10 mm; Pass \_\_\_\_\_ Fail \_\_\_\_\_

---

## 7.0 Software

By January 2008, the software for all BGI electronic calibrators has been replaced by a completely new suite known as BGI Open. This suite and a complete instruction manual may be downloaded at: [http://www.bgiusa.com/cal/bgi\\_open.htm](http://www.bgiusa.com/cal/bgi_open.htm)

## 8.0 Maintenance

Beyond battery replacement, the only part of the instrument requiring attention is the flow passage through the venturi. After *long* periods of use, some atmospheric dust can coat the interior flow surfaces. The presence of such a deposit may be ascertained by viewing the interior of the venturi under bright light; direct overhead sunlight being preferable. Glance into the interior, from either end, seeking any discoloration of the white or silver surface. If it is determined that cleaning is required, use the following procedure.

Rinse the entire venturi body in warm soapy water. Any deposits, which are not floated away, may be removed externally with a soft cloth. If internal deposits are not removed by soaking, the best procedure is to immerse the unit in an ultrasonic bath containing soapy water. If an ultrasonic bath is not available, *judicious* use of a pipe cleaner is recommended. Following cleaning, the venturi may be dried utilizing compressed air, or if not available, allowed to air dry.

Inspect the two "O" rings on the venturi body. If any damage is observed, replace both. Prior to reassembly, lubricate the "O" rings with a wipe of Grease (Appendix 3).

## 9.0 Safety

There are no owner serviceable components in the instrument other than the venturi, "O" rings described in the previous section and the four AA batteries. These should only be replaced with good quality alkaline energy cells and should be promptly removed when expired, to prevent leakage and chemical damage to the electronic components. When the instrument is placed in long term storage (more than two months) always remove the batteries.

Do not substitute other power supplies. Use only the unit provided, or severe electrical problems will occur.

Even though there is no reason to disassemble the electronics box, should the need arise, always unplug the line current power supply (if it is in use) and remove the batteries.

Adjustable potentiometers are contained within the electronic housing, which are factory set during calibration. If these are turned, the calibration will be lost and factory recalibration will be required.

## **10.0 Warranty Information**

BGI warrants equipment of its manufacture and bearing its nameplate to be free from defects in workmanship and material. We make no warranty, express or implied, except as set forth herein. BGI's liability under this warranty extends for a period of one (1) year from the date of BGI's shipment. It is expressly limited to repairing or replacing at the factory during this period and at BGI's option, any device or part which shall within one year of delivery to the original purchaser, be returned to the factory, transportation prepaid and which on examination shall in fact be proved defective.

BGI assumes no liability for consequential damages of any kind. The purchaser, by acceptance of this equipment, shall assume all liability for consequences of its misuse by the purchaser, his employees or others. This warranty will be void if the equipment is not handled, installed, or operated in accordance with our instructions. If damage occurs during transportation to the purchaser, BGI must be notified immediately upon arrival of the equipment. The Equipment will be returned via collect shipment.

A defective part in the meaning of this warranty shall not, when such part is capable of being repaired or replaced, constitute a reason for considering the complete equipment defective. Acknowledgment and approval must be received from BGI prior to returning parts or equipment for credit. BGI makes engineering changes and improvements from time to time on instruments of its manufacture. We are under no obligation to retrofit these improvements and/or changes into instruments which have already been purchased.

No representative of ours has the authority to change or modify this warranty in any respect.

## **Appendix A. NIST Traceability**

### **A1.0 Introduction**

NIST traceability for the calibrator is established with the use of devices which are of themselves traceable and for which, BGI holds current traceability certificates. Calibrations are performed under a set of ISO 9000-2008 procedures, subject to annual audit. During a flow rate calibration, the room temperature is established with an ASTM certified/traceable thermometer. Barometric pressure and absolute pressure are established with electronic manometers. These are backed by three Primary Standard Mercury Instruments/

### **A2.0 Flow Rate Calibration**

A schematic diagram of an instrument undergoing flow rate calibration is shown in Figure 1A. Three traceable critical Venturi are utilized for this purpose. Their details are listed on the calibration certificate. Readings of flow rate are taken as shown in Figure A2, which is a typical calibration. While the calibrator utilizes barometric pressure and ambient temperature to constantly display readings of volumetric flow rate, the initial venturi calibration is performed and normalized to a base value. While any values are sufficient, "Engineering Standard Values" of 20C and 760mm of Hg have been selected. Utilizing an Excel spreadsheet, the flow rate vs.

pressure drop equation for each individual venturi, under test, is determined. This equation is then installed in the individual units microprocessor.

### **A3.0 Barometric Pressure Calibration**

The barometric pressure sensor is set to match the actual current barometric pressure as determined by a Mercury barometer. A negative pressure of 150 mm of Hg is applied to the barometric pressure transducer and the output reading is adjusted to comply with BP – 150mm.

### **A4.0 Temperature Calibration**

The Thermistor provided for measurement of ambient temperature is of a very high standard and are batch tested at the temperature extremes of –20 C and +55 C, utilizing an ASTM certified/traceable thermometer as a reference.

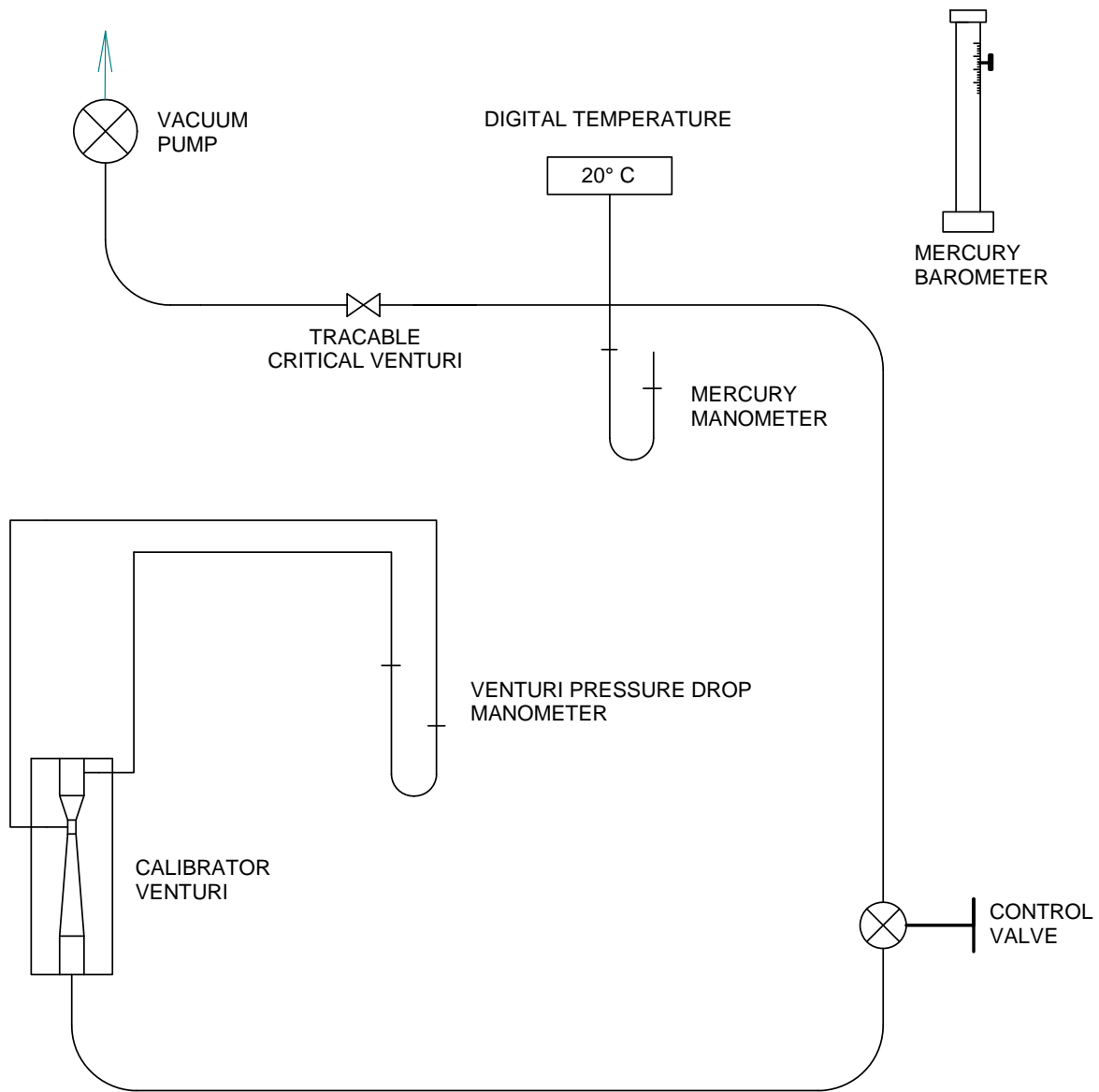

2313

Figure A1 – Schematic Diagram of Calibration Setup

## **A5.0 Recalibration**

Recalibration is immediately necessary if physical damage has occurred to such an extent that the instrument is rendered inoperable. In such cases, an instrument will be recalibrated as part of the repair procedure. There are no moving or wear parts in the instrument, therefore, barring physical damage, there is no reason for recalibration, except as required by ISO, company or regulatory requirements. These requirements are almost universally on a one-year basis, after being placed in service. Units received for recalibration will be thoroughly inspected and any requisite repairs will be performed prior to recalibration.

## **Appendix B. Lubrication**

There are two points which require careful lubrication. These points are the two "O" rings at the top of each venturi to which the tubing adapter is attached and the four "O" rings inside the socket into which the venturi is inserted. They should be sparingly lubricated with the tip of the finger. General purpose automotive grease seems to be the most successful all around lubricant.

## **References**

1. Fan Engineering, R. Jorgensen, ed. Buffalo Forge Co, Buffalo, NY. 6<sup>th</sup> Ed. 1961.
2. US EPA FRM 40 CFR Part 53, Federal Register, July 18, 1997.
3. Measurement Systems, E.O. Doebelin, McGraw-Hill Inc., New York, NY. 4<sup>th</sup> Ed. 1990.

## **Revision History**

Version 1.0.0

First public release

May 2009