



**High Volume Field Audit Calibrator
Single Range Model HVC1 (7 to 54 CFM)**

*With Appendix for Metric Versions
Single Range Model HVC8 (0.2 to 1.53 M³/min)
Single Range Model HVC9 (200 to 1530 LPM)*

NIST Traceable – ISO 9001:2008

BGI Incorporated
58 Guinan Street
Waltham, MA 02451
Tel: 781.891.9380
Fax: 781.891.8151
www.bgiusa.com
info@bgiusa.com

Table of Contents.

Section	Topic	Page
1.0	Quick Start	3
2.0	Introduction	3
3.0	Specifications	5
4.0	Principle of Operation	9
5.0	Instrument Set Up	9
6.0	Using the HiVolCal	12
7.0	Software	12
8.0	Maintenance	12
9.0	Safety	12
10.0	Warranty	13
Appendix A	NIST Traceability	14
Appendix B	Qs/Qa Relationship	16
Appendix C		17
Revision History		18

1.0 Quick Start

In order to put the HiVolCal to immediate use as an Audit device, follow these steps.

Step 1: Remove the HiVolCal from its carrying case and turn it on.

Step 2: Remove the inlet, if any, from your sampler.

Step 3: Install the HiVolCal measuring head directly on your sampler or utilize the optional adaptor. It is normal to audit/calibrate with a clean filter in place.

Step 4: Start the sampler under investigation.

Step 5: You may now read the HiVolCal screen to determine volumetric flow rate, standard flow rate, ambient temperature and barometric pressure.

For a diagram of the immediate application refer to Figure 1.

2.0 Introduction

The BGI HiVolCal is a flow audit device compatible with EPA FRM samplers and other High Volume devices, based on the measurement principle of the orifice¹. It was developed by BGI and is manufactured in BGI's ISO 9001:2000 facility. It provides a LCD indication of *volumetric* flow rate, *standard* flow rate, barometric pressure and ambient temperature. It operates on four AA alkaline energy cells. The electronics are all housed in the control module.

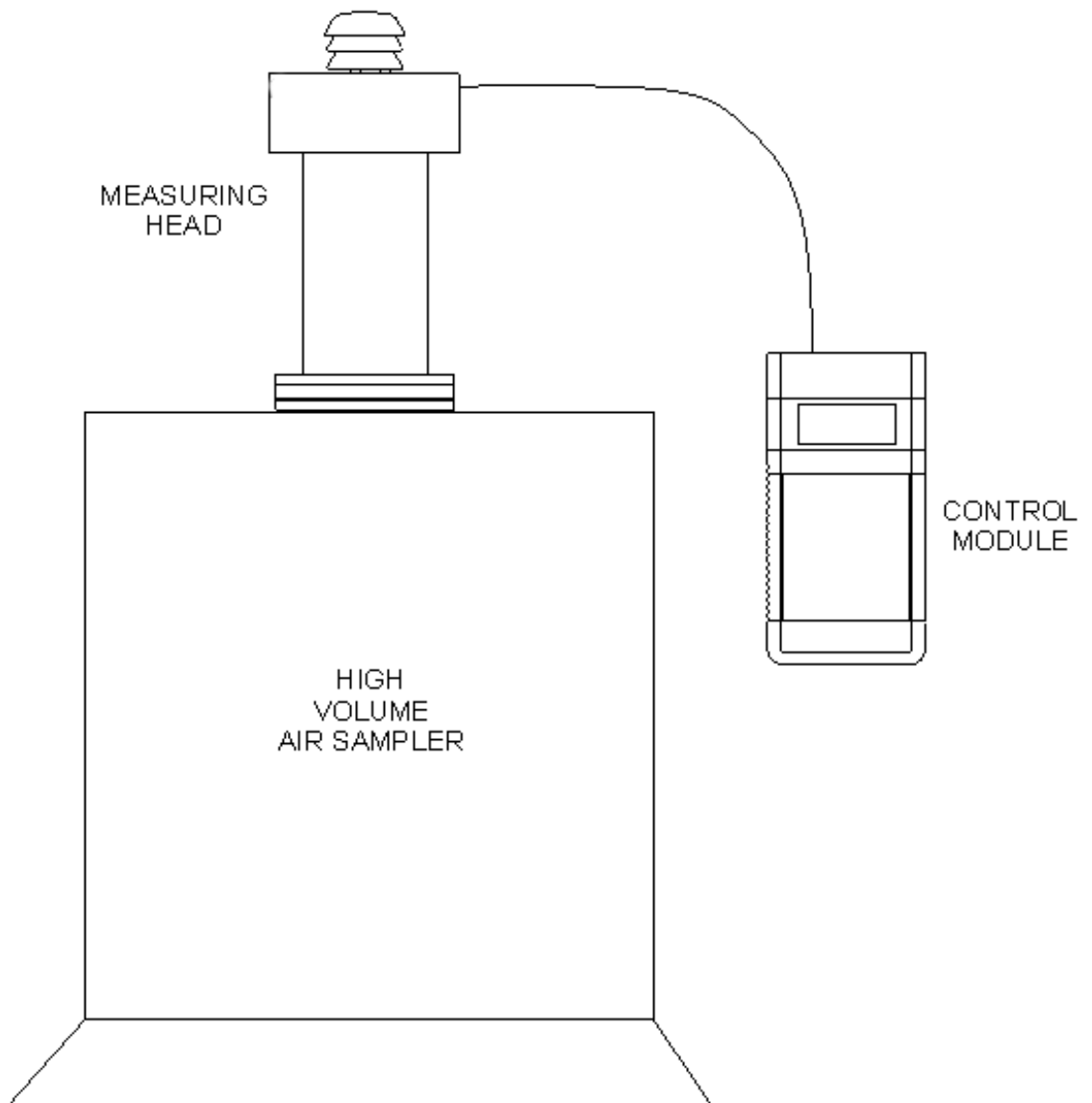

Figure 1 - Instalation of HiVolCal on Sampler

3132

3.0 Specifications

Flow rate range:	7 – 54 CFM ($\pm 1\%$)
Temp. Operational range	-30° C to 55° C
Temp. Reading range	-30° C to 55° C ($\pm 0.5^\circ$ C)
Barometric pressure range	400 to 800 mm of Hg (± 5 mm)

Dimensions:

Measuring Head	4.5 in. Max OD (11.4 cm) X 9.5 in. high (24.1 cm)
Control Module	8 in. high (20.3 cm) X 4 in. wide (10.15 cm) X 1.7 in. thick (4.32 cm)
Combined weight	2.2 lbs (1 kg)

Carrying case:

Dimensions:	18 in wide (45.7 cm) X 13 in high (33 cm) X 7 in. thick (17.8 cm)
-------------	---

Weight complete with contents:	5.5 lbs (2.5 kg)
--------------------------------	------------------

One complete instrument comprises:

Quantity	Description	Catalog/Part No.
1	HiVolCal	HVC1
4	Extra AA batteries	replacements obtained locally by user
1	Instruction Manual	Download PDF file from BGI website
1	Fitted Hard Carrying Case	HVC4

The HiVolCal, in its carrying case is shown in figure 2

Replacement supplies (not included with initial purchase).

1	Base Gasket	HVC6
1	Adaptor f/ "2 Inch" filter holder	3114

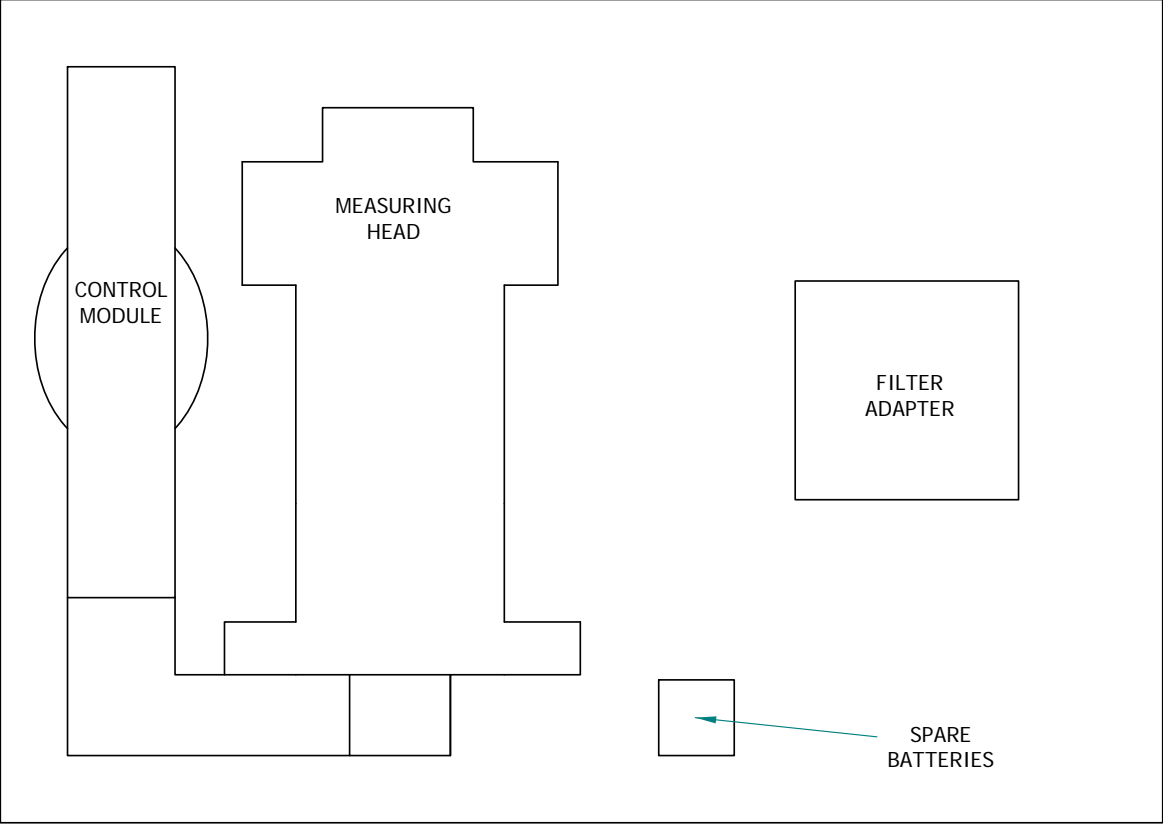

Figure 2- HiVolCal In Travel case

3133

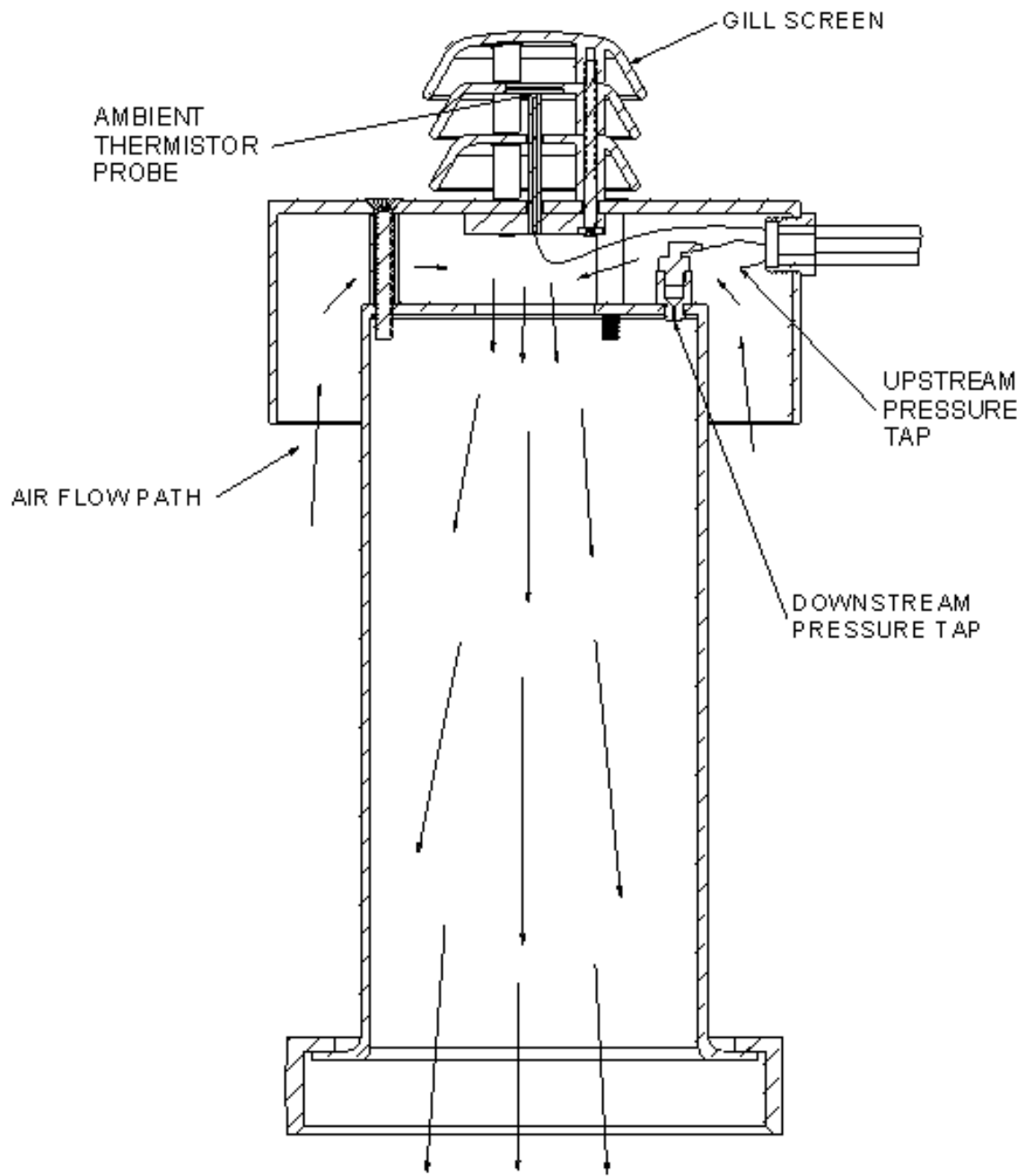

Figure 3 - Sectional View of Flow measuring Head

3134

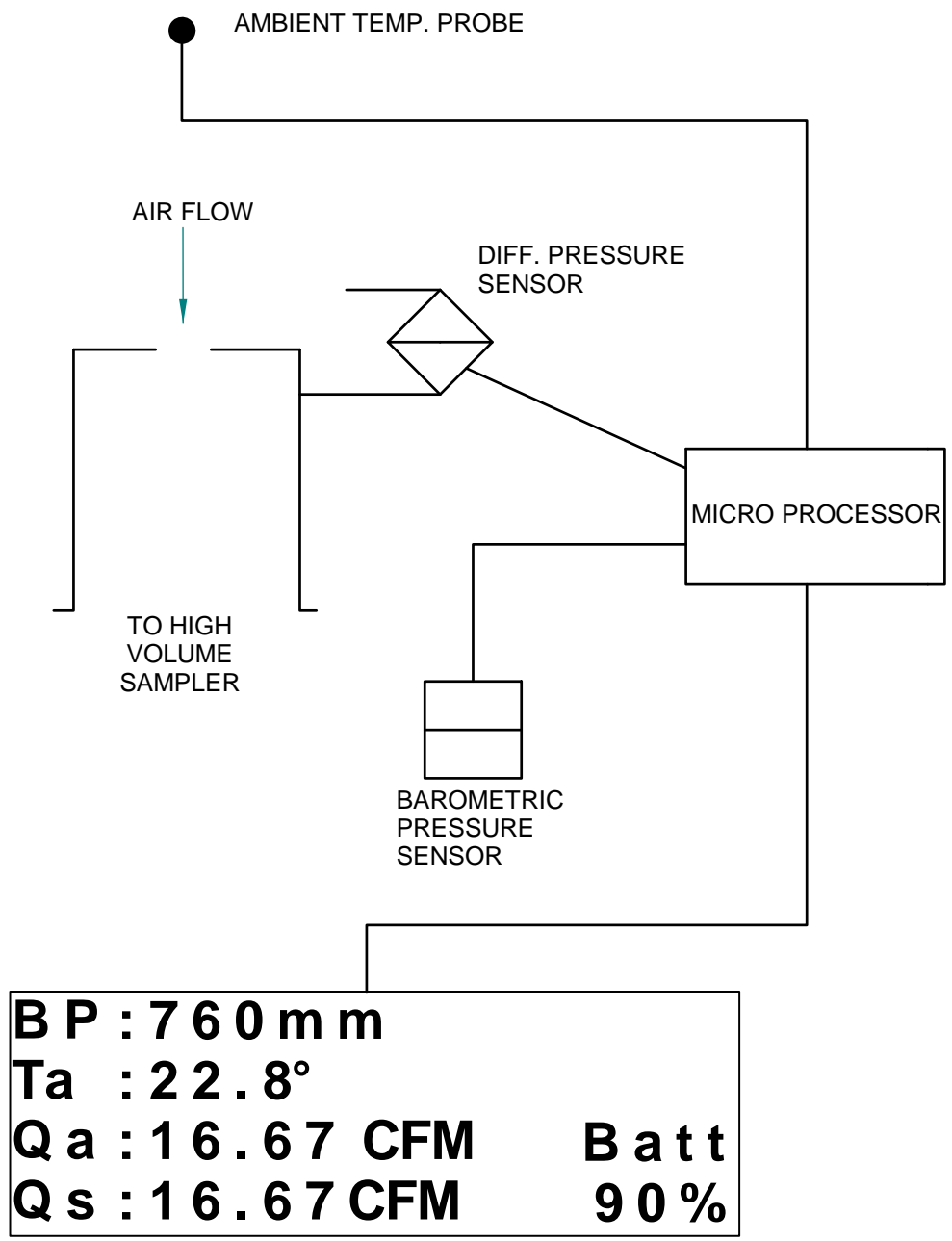

Figure 4- Schematic Diagram of HiVolCal

3135

4.0 Principle of Operation

The HiVolCal measures volumetric and standard flow rate by utilizing a pressure transducer to assess the pressure drop caused by air being drawn through an orifice. As the flow rate through the orifice increases the pressure drop increases as the square root¹. A four times increase in pressure drop yields twice the flow rate. A desirable feature of the orifice is that 60% of the pressure drop created by the instrument is recovered downstream of the orifice. Therefore, measurements are made reasonably near the operating conditions of the sampler.

The signal from the pressure transducer is sent to the microprocessor where, it is combined, via an algorithm with information from the barometric pressure sensor and the ambient temperature sensor. To eliminate “fluttering” of the on screen display of flow rate, the first 20 readings are averaged and then carried on as a rolling average. Barometric pressure and temperature are monitored and displayed on a continuous basis, when the instrument is switched on. A cutaway diagram of the measuring head is shown in figure 3 and a schematic diagram of the system is shown in Figure 4.

5.0 Instrument Set-up

Important points to be noted concerning the utilization of the HiVolCal

- A. The measuring head must have no air flowing through it.

Every time the instrument is switched on, it re-zeros itself. If air is flowing, that flow rate will be set as zero.

- B. The control module must be in the position in which it is going to be used, when switching on. (Horizontal or vertical). The case houses the pressure transducers, which are subject to the force of gravity. Positional changes can give rise to minor errors. This effect applies to all devices containing pressure transducers.
- C. In order to perform the most precise measurement audit, it is necessary for the HiVolCal to be in thermal equilibrium with the ambient environment in which the sampler to be audited is located. The best procedure is to deploy the HiVolCal, out of its carrying case, for 10 minutes prior to the audit. Additionally, *if the HiVolCal is subject to a temperature change of more than five degrees during use, it should be rebooted.*

When the HiVolCal is switched on *XX* % battery capacity remaining is displayed on the screen. So long as more than 10% is indicated, it is safe to proceed in that at least one hour of power is available. The audit is now ready to be performed.

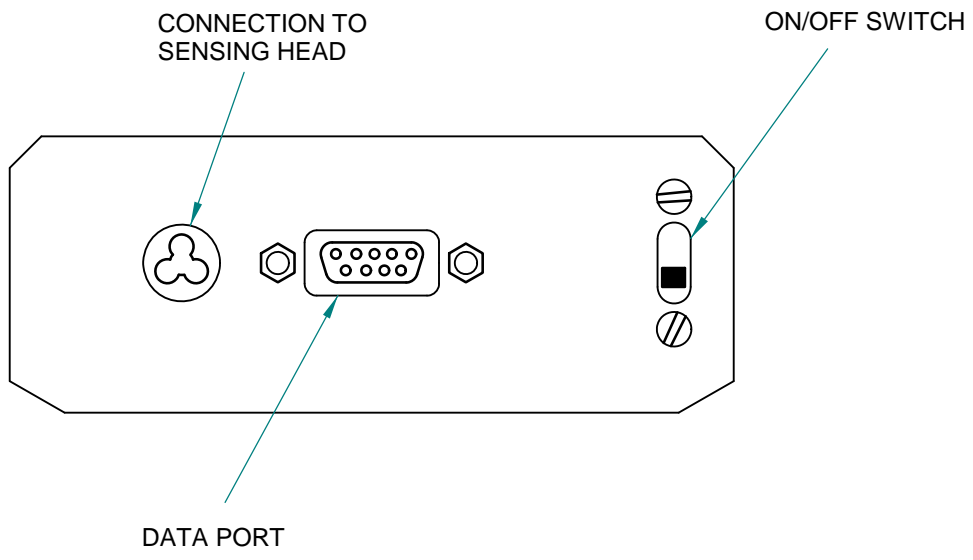

Figure 5- HiVoICAL Control Panel

3136

Table 1 Audit Data Format

Audited Instrument:

Make: _____ Model: _____ S/N: _____

Date: _____ Time: _____ HiVolCal S/N: _____

Flow Rate – Lpm

Sampler: _____

% diff. = [(HiVolCal-sampler)/HiVolCal]x100

HiVolCal: _____

Allowed diff. = 4%; Pass _____ Fail _____

Ambient Temp. – C

Sampler: _____

HiVolCal: _____

Allowed diff. = ± 2 C; Pass _____ Fail _____

Barometric Pressure – mm of Hg

Sampler: _____

HiVolCal: _____

Allowed diff. = ± 10 mm; Pass _____ Fail _____

6.0 Using the HiVolCal

6.1 To perform an audit

Turn *off* the sampler to be audited. Remove the inlet of the sampler and install the HiVolCal. Use adaptor as necessary. Turn *on* the HiVolCal, wait for the screen to finish the startup boot, *and then* turn on the air sampler.

The flow resistance of the HiVolCal head may cause momentary instability in the air samplers flow control circuit. Once the air samplers main screen flow rate indicator stabilizes, the reading may be taken. A simple audit data format is shown in Table 1.

6.2 To perform a calibration.

The procedures and calculations for using the HiVolCal to calibrate a sampler are the same as an audit, *except* the flow rate tolerance of is usually $\pm 2\%$ rather than $\pm 4\%$ as suggested for an audit.

7.0 Software

By January 2008, the software for all BGI electronic calibrators has been replaced by a completely new suite known as BGI Open. This suite and a complete instruction manual may be downloaded at: http://www.bgiusa.com/cal/bgi_open.htm

8.0 Maintenance

Beyond battery replacement, the only part of the instrument requiring attention is the base gasket. It must be maintained in perfect condition in order to maintain an airtight seal.

As with all calibration instruments, it is essential that they be handled with care and kept clean. At the first sign of damage their use should be discontinued and it should be returned for inspection/repair.

Recalibrations should be performed on an annual basis.

9.0 Safety

There are no owner serviceable components in the measuring head of the instrument other than the gasket. The only user serviceable items in the electronic control module are the four AA batteries. These should only be replaced with good quality alkaline energy cells and should be promptly removed when expired, to prevent leakage and chemical damage to the electronic components. When the instrument is placed in long term storage (more than two months) always remove the batteries.

Even though there is no reason to disassemble the electronics box, should the need arise, always remove the batteries.

Adjustable potentiometers are contained within the electronic housing, which are factory set during calibration. If these are turned, the calibration will be lost and factory recalibration will be required.

10.0 Warranty Information

BGI Incorporated warrants equipment of its manufacture and bearing its nameplate to be free from defects in workmanship and material. We make no warranty, express or implied, except as set forth herein. BGI's liability under this warranty extends for a period of one (1) year from the date of BGI's shipment. It is expressly limited to repairing or replacing at the factory during this period and at BGI's option, any device or part which shall within one year of delivery to the original purchaser, be returned to the factory, transportation prepaid and which on examination shall in fact be proved defective.

BGI assumes no liability for consequential damages of any kind. The purchaser, by acceptance of this equipment, shall assume all liability for consequences of its misuse by the purchaser, his employees or others. This warranty will be void if the equipment is not handled, installed, or operated in accordance with our instructions. If damage occurs during transportation to the purchaser, BGI must be notified immediately upon arrival of the equipment. The Equipment will be returned via collect shipment.

A defective part in the meaning of this warranty shall not, when such part is capable of being repaired or replaced, constitute a reason for considering the complete equipment defective. Acknowledgment and approval must be received from BGI prior to returning parts or equipment for credit. BGI Incorporated makes engineering changes and improvements from time to time on instruments of its manufacture. We are under no obligation to retrofit these improvements and/or changes into instruments which have already been purchased.

No representative of ours has the authority to change or modify this warranty in any respect.

Appendix A. NIST Traceability

A1.0 Introduction

NIST traceability for the HiVolCal is established with the use of devices which are of themselves traceable and for which, BGI holds traceability certificates. Calibrations are performed under a set of ISO 9000-2000 procedures, subject to annual audit. During a flow rate calibration, the room temperature is established with an ASTM certified/traceable thermometer. Barometric pressure and absolute pressure are established with electronic manometers. These are backed by three Primary Standard Mercury Instruments.

A2.0 Flow Rate Calibration

A schematic diagram of an instrument undergoing flow rate calibration is shown in Figure 1A. A standard "EPA type" Dresser Roots meter is used for the purpose. Readings of flow rate are used to determine the constants of the calibration curve. While the HiVolCal utilizes barometric pressure and ambient temperature to constantly display readings of volumetric flow rate, the initial orifice calibration is performed and normalized to a base value. While any values are sufficient, "engineering standard values" of 20C and 760mm of Hg have been selected and are the reporting basis for NIST calibrations. The flow check sheet furnished with each calibrator and recalibration presents three flow rates. 1) The calibration flow rate standardized to Sea level and $T_s=20\text{ C}$. 2) The EPA Flow rate standardized to sea level and $T_s=25\text{ C}$. This is shown on the screen as **Qs**. 3) The actual flow rate at the BP and T_a at the time of calibration, shown on the screen as **Qa** Utilizing an Excel spreadsheet, the flow rate vs. pressure drop equation for the individual orifice under test is determined. This equation is then installed in the individual unit's microprocessor. All the various figures are shown on the calibration Check Sheet.

A3.0 Barometric Pressure Calibration

The barometric pressure sensor is set to match the actual current barometric pressure as determined by a Reference Standard barometer. A negative pressure of 150 mm of Hg is applied to the barometric pressure transducer and the output reading is adjusted to comply with $BP - 150\text{mm}$.

A4.0 Temperature Calibration

The Thermistors provided for measurement of ambient and filter temperature are of a very high standard and are batch tested at the temperature extremes of -20 C and $+50\text{ C}$, utilizing an ASTM certified/traceable thermometer as a reference.

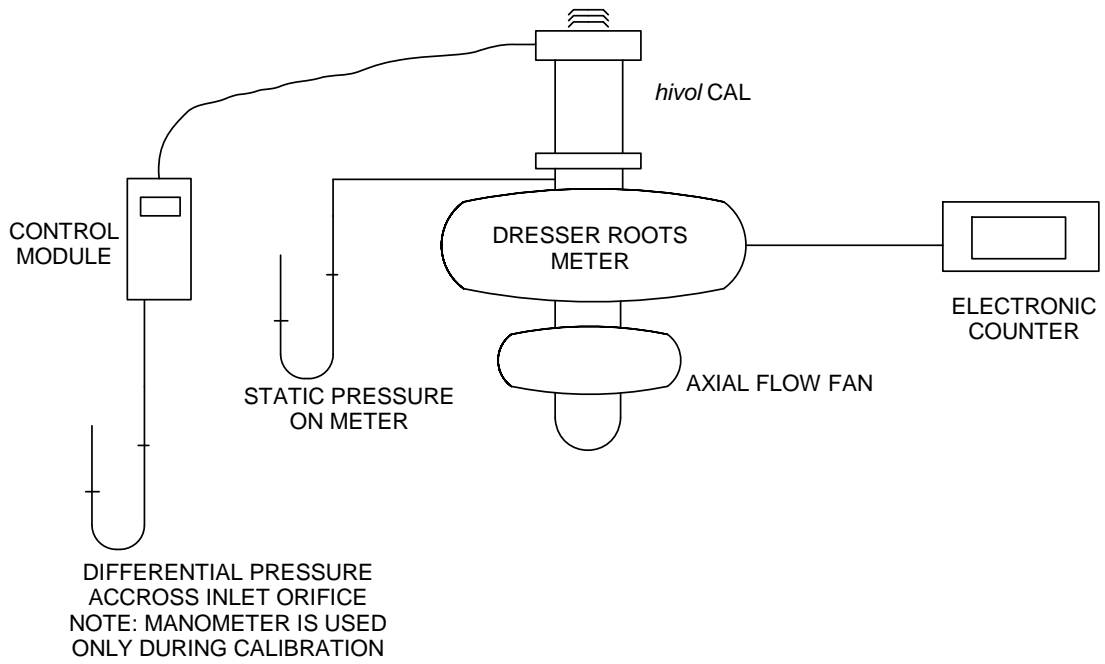

Figure A1 - Schematic Diagram of Calibration Setup

3137

A5.0 Recalibration

Recalibration is immediately necessary if physical damage has occurred to such an extent that the instrument is rendered inoperable. In such cases, an instrument will be recalibrated as part of the repair procedure. There are no moving or wear parts in the instrument, therefore, barring physical damage, there is no reason for recalibration, except as required by ISO, company or regulatory requirements. These requirements are almost universally on a one-year basis, after being placed in service. Units received for recalibration will be thoroughly inspected and any requisite repairs will be performed prior to recalibration.

Appendix B. Qs/Qa Relationship

EPA, for Politico Legal, reasons uses **Q_s** known as **Standard** Air flow rate for reporting PM₁₀. This means that the flow rate is reported to **Standard** conditions. For the US EPA, these conditions are 25 C and 1 atmosphere pressure. (1 Atmosphere = 760 mm of Hg = 29.92 in of Hg = 1013.25 millibars = 1013.25 hecto Pascals).

Because the mass of air flowing could be calculated from Q_s it has come to be called **Mass flow**. Throughout most of the world Q_s is not usually referred to as mass flow and it is to a different standard. The conditions outside of the U.S. are 0 C and 1013.25 mb.

Volumetric devices are in the majority and any of them may be used to measure Q_s if there is also knowledge of the T and BP, in the immediate locale, either from the instrument itself or supplemental instruments.

$$Q_s = Q_a * (BP_a/760)*(298.15/T_a+273.15) \text{ For U.S. applications when } T_s=25 \text{ C and } BP_s=760 \text{ mm of Hg}$$

$$Q_s = Q_a * (BP_a/1013.25)*(273.15/T_a) \text{ For world applications when } T_s=0 \text{ C and } BP_s=1013.25 \text{ mb}$$

Inasmuch as the HiVolCal generates Q_a, T_a and BP information on a continuous basis the code is written to provide both **Q_a** and **Q_s** information. At the same time, the two most popular Barometric pressure units (mm of Hg and millibars or hecto Pascals) are also provided. This results in two new screens;

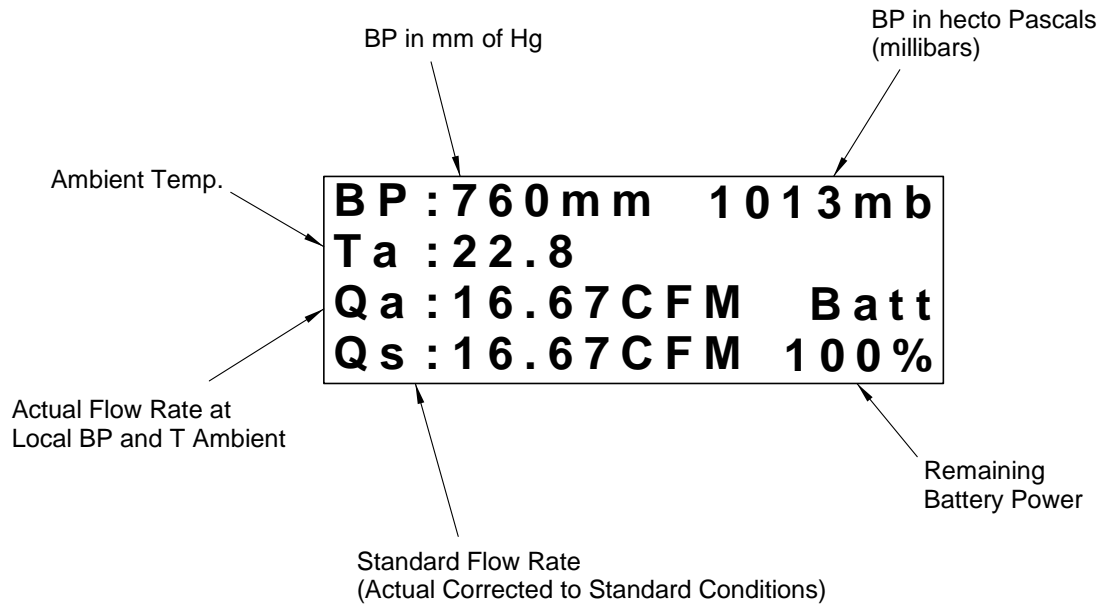

3138

Remember, Qs is always set to sea level conditions, but the Standard temperature is always factory set to either **25 C** (US EPA, Canada and other countries using US EPA conditions) or **0 C**. If the Firmware version contains the letter **W** (for world) the temperature base is **0 C**.

Appendix C. Metric Versions

The part number of the instrument heretofore described in this manual is: **HVC1**.
It displays flow rate as:

Q actual in cubic feet per minute. That is the flow rate at the *instantaneous* conditions of Barometric pressure and temperature. Also written as **Q_A**, **BP_A** and **T_A**

Q standard in cubic feet per minute. That is the flow rate at the *standard* conditions of Barometric pressure at sea level and Temperature of 25 C. This temperature is unique to the US EPA. Also written as **Q_S**, **BP_S** and **T_S**

Two other part numbers have been added to cover the demands of users requiring the flow rate to be expressed in Metric units. For US EPA requirements we have created **HVC8**

It displays flow rate as:

Q actual in cubic meters per minute. That is the flow rate at the *instantaneous* conditions of Barometric pressure and temperature. Also written as **Q_A**, **BP_A** and **T_A**

Q standard in cubic meters per minute. That is the flow rate at the *standard* conditions of Barometric pressure at sea level and Temperature of 25 C. This temperature is unique to the US EPA. Also written as **Q_S**, **BP_S** and **T_S**

A part number has been created for applications in Europe and other parts of the world where the standard temperature is taken as **0 C**. The number is **HVC9**

It displays flow rate as:

Q actual in liters per minute. That is the flow rate at the *instantaneous* conditions of Barometric pressure and temperature. Also written as **Q_A**, **BP_A** and **T_A**

Q standard in liters per minute. That is the flow rate at the *standard* conditions of Barometric pressure at sea level and Temperature of **0 C**. This temperature is unique to the US EPA. Also written as **Q_S**, **BP_S** and **T_S**

Summary:

If a calibrator reads flow rate in CFM or CMM it is to EPA specifications. $T_S = 25\text{ C}$

If a calibrator reads flow rate in LPM it is to World Specifications. $T_S = 0\text{ C}$

References

1. Fan Engineering, R. Jorgensen, ed. Buffalo Forge Co, Buffalo, NY. 6th Ed. 1961.
2. US EPA FRM 40 CFR Part 53, Federal Register, July 18, 1997.
3. Measurement Systems, E.O. Doebelin, McGraw-Hill Inc., New York, NY. 4th Ed. 1990.

Revision History

Version 1.0.1	First public release	December 2008
Version 1.0.2	Revised Part Numbers	January 2009
Version 1.0.3	Updated ISO Registration	March 2009
Version 1.0.4	Added Appendix C	December 2009