



**BGI, INC.**  
WALTHAM, MA 02451

JANUARY, 2002

58 Guinan Street Waltham, MA 02451

Tel: 781-891-9380 Fax: 781-891-8151

## **COLLISON NEBULIZER – INSTRUCTIONS**

### *MRE 1, 3, 6 and 24 Jet*

#### **1. Introduction**

The Collison Nebulizer was first described in the scientific literature by Collison in 1935, according to May<sup>(1)</sup>. Over the intervening years, it has become the recognized technique for atomizing liquids and suspensions. The original version had 3 jets and BGI is responsible for the standardization and publication of the 6 jet version<sup>(2)</sup>.

Nebulization is taken to mean a refinement of two fluid atomization. In an atomizer, a gas is used to aspirate the liquid into a (usually) sonic velocity gas jet, wherein it is sheared into droplets. In a Nebulizer, this liquid/gas jet is impacted against a barrier (the inside of the jar) to remove the larger fraction of the droplets.

There is one basic type of Collison Nebulizer, known as the modified MRE, which is manufactured by BGI. MRE stands for Microbiological Research Establishment, located in Porton, England.

All Collison Nebulizers of current BGI manufacture, have all the metal components fabricated from 316 stainless steel. All "O" rings are buna N or silicone rubber. No flat gaskets are currently utilized. Glass jars are either Crown Glass (standard) or Pyrex (precious fluids jar only). The 24 jet Collison jar is coated with clear PVC.

#### **2. Safety Precautions**

While the recommended pressure to be applied to the nebulizer may vary from 20 to 100 psig., it must be clearly understood that this pressure is expanded to just above atmospheric, inside the jar. ***The glass jar is not to be subjected to pressures above 1 psig under any circumstances!*** Great care must be exercised at all times when connecting the nebulizer's output to other apparatus, to ensure that the flow of gas out of the nebulizer is not restricted in any manner that will cause significant back pressure.

The Collison Nebulizer is intended to be utilized by trained scientific professionals. BGI will bear no responsibility for misuse.

#### **3.0 Set up**

3.1 Air. It is the responsibility of the investigator to supply a source of clean, compressed air. The volumetric requirements as follows:

Pressure psig	Volume of Free Air in LPM			
	1-Jet	3-Jet	6-Jet	24-Jet
20	2	6	12	48
40	3.3	10	20	80
60	4.5	13.5	27	Not Recommended
80	5.8	17.3	34.5	Not Recommended
100	7	21	42	Not Recommended

It is recommended that a precision pressure gage be fitted to the plugged end of the "T". This may be accomplished by removing the plug screw by hand. A schematic diagram of the basic set up is shown in figure 1. All parts are shown in Figure 2.

### **3.2 Liquid Level**

No specific liquid level is recommended. This is because the "T" may be pulled up or pressed down to a variety of positions. The important point is to begin with the tip of the nozzle immersed no more than 3/8 of an inch below the surface. Deeper immersion will cause the surface of the liquid to interfere with the formation of the jet. For clarification of this point see Figure 3.

### **3.3 Cleaning**

Basic cleaning functions can be performed by disconnecting the apparatus from the air hose and removing and emptying the jar. All components can then be immersed in a cleaning solution appropriate to the material being aerosolized. Ultrasonic cleaning is highly recommended.

The nozzle may be removed from the "T" stem by hand (since 1996). A small, custom made, "O" ring is fitted to the stem, in a groove above the threads, to seal the juncture.

If an internal jet becomes plugged, it may be cleared with the clean out drill (CN-11) supplied with all new units.

### **4.0 Precious Fluids Jar**

This is a fabricated pyrex jar, which has a 5 ml well formed into the bottom. It may be used as a replacement for the standard jar. However, it must be utilized in conjunction with the extension sleeve (CN-41) to the bottom of the nozzle. the purpose of the sleeve is to permit the nozzle to operate in a position sufficiently elevated such that the spray does not interact with the bottom of the jar. Its application is best illustrated by viewing Figure 4. The sleeve is slotted to permit bending the tabs thus formed, inwards for the purpose of achieving a firm fit between the sleeve and the nozzle.

### **5.0 External Fill Adaptor**

The purpose of the external fill adaptor is to permit the addition of liquid while the Collision is running. Replacement liquid can not simply be poured into the jar through a fill hole because there is a slight pressure inside the jar and pouring liquid past the jets may cause unaccountable difficulties with the aerosol production.

The external fill adaptor (CN-42) comprises a luer bulkhead adaptor and cap fitted with a long section of thin tubing. All current production lids have a threaded hole fitted with a plug screw. All current production nozzles have an extra (2<sup>nd</sup>, 4<sup>th</sup> or 7<sup>th</sup>) hole to guide the thin tube into the nozzle. Each CN-42 is supplied with an "O" ring and lock nut. The application of this device is illustrated in Figure 5.

### **6.0 Further Information**

The best "cookbook" reference of the application of the Collision Nebulizer is and remains the one by May<sup>(1)</sup>. Because of the universal acceptance and use of this device, references in aerosol-related literature are constantly occurring and should be consulted when appropriate or necessary.

The 24 Jet Collision is a recent development, not presently described in the literature. It is not intended for external fill nor precious fluid applications.

## 7.0 Component Parts List – Fig. 2

### 1, 3 and 6 Jet

CN 24/1J	Jet (1)		
CN 24 J	Jet (3)	CN 48	“T” Stem
CN 25 J	Jet (6)	CN 49	“O” Ring
CN 27	Bottle	CN 50	Compression Nut
CN 40	Precious Fluids Bottle	CN 51	Conical Ferrule - TFE
CN 39	“O” Ring - Silicone	CN 52	Ferrule, Flat-SS
CN 43	Plug Screw	CN 53	Lid
CN 44	“O” Ring	CN 54	“O” Ring
CN 47	Nut		

### 24 Jet

Only those parts unique to the 24 jet model, CN-60 are listed below (see figure 6). Other components are common with the 3 and 6 jet models.

CN 61	“O” Ring - Lid	CN 65	Lid
CN 62	“O” Ring – Body	CN 66	Body Cover
CN 63	Jar	CN67	Jet Body
CN 64	“T” Stem		

## 8.0 Disclaimer

The Collision Nebulizer is subject to all the terms of BGI Incorporated standard limited warranty. The nebulizer is a specialized article of research equipment intended for use by trained professionals. No liability is accepted by BGI Incorporated on account of misuse, misapplication or mishandling. BGI Incorporated specifically does not condone nor endorse any application or use which involves restricting emissions from the device and thus causing pressurizing of the jar. Further, BGI Incorporated accepts no liability for exposure to toxic, infectious or harmful substances resulting from the use of this apparatus.

### **Limited Warranty**

BGI Incorporated warrants equipment of its manufacture and bearing its nameplate to be free from defects in workmanship and material. We make no warranty, express or implied, except as set forth herein.

BGI's liability under this warranty extends for a period of one (1) year from the date of BGI's shipment. It is expressly limited to repairing or replacing at the factory during this period and at BGI's option, any device or part which shall within one year of delivery to the original purchaser, be returned to the factory, transportation prepaid and which on examination shall in fact be proved defecting. BGI assumes no liability for consequential damages of any kind. The purchaser, by acceptance of this equipment, shall assume all liability for consequences of its misuse by the purchaser, his employees or others. This warranty will be void if the equipment is not handled, installed, or operated in accordance with our instructions. If damage occurs during transportation to the purchaser, BGI must be notified immediately upon arrival of the equipment. The Equipment will be returned via collect shipment.

A defective part in the meaning of this warranty shall not, when such part is capable of being repaired or replaced, constitute a reason for considering the complete equipment defective. Acknowledgment and approval must be received from BGI prior to returning parts or equipment for credit.

No representative of ours has authority to change or modify this warranty in any respect.

### References:

1. May K.R. (1973) The Collision Nebulizer. Description, Performance & Application J. of Aerosol Science, Vol. 4, #3, P. 235.
2. Gussman, R.A. (1984) Note on the Particle Size Output of Collision Nebulizers, Am. Ind. Hyg. Assoc. J. (45).

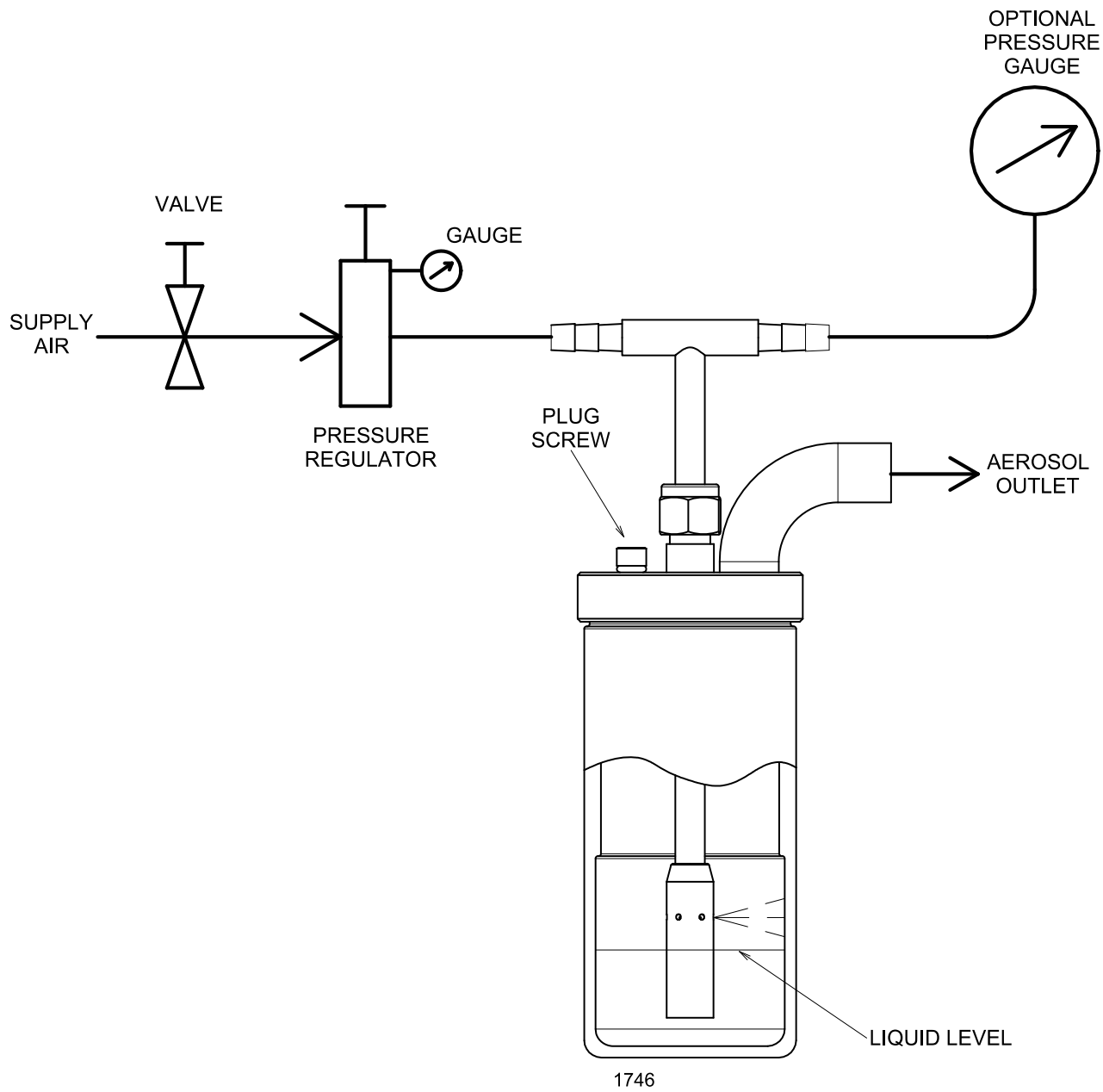
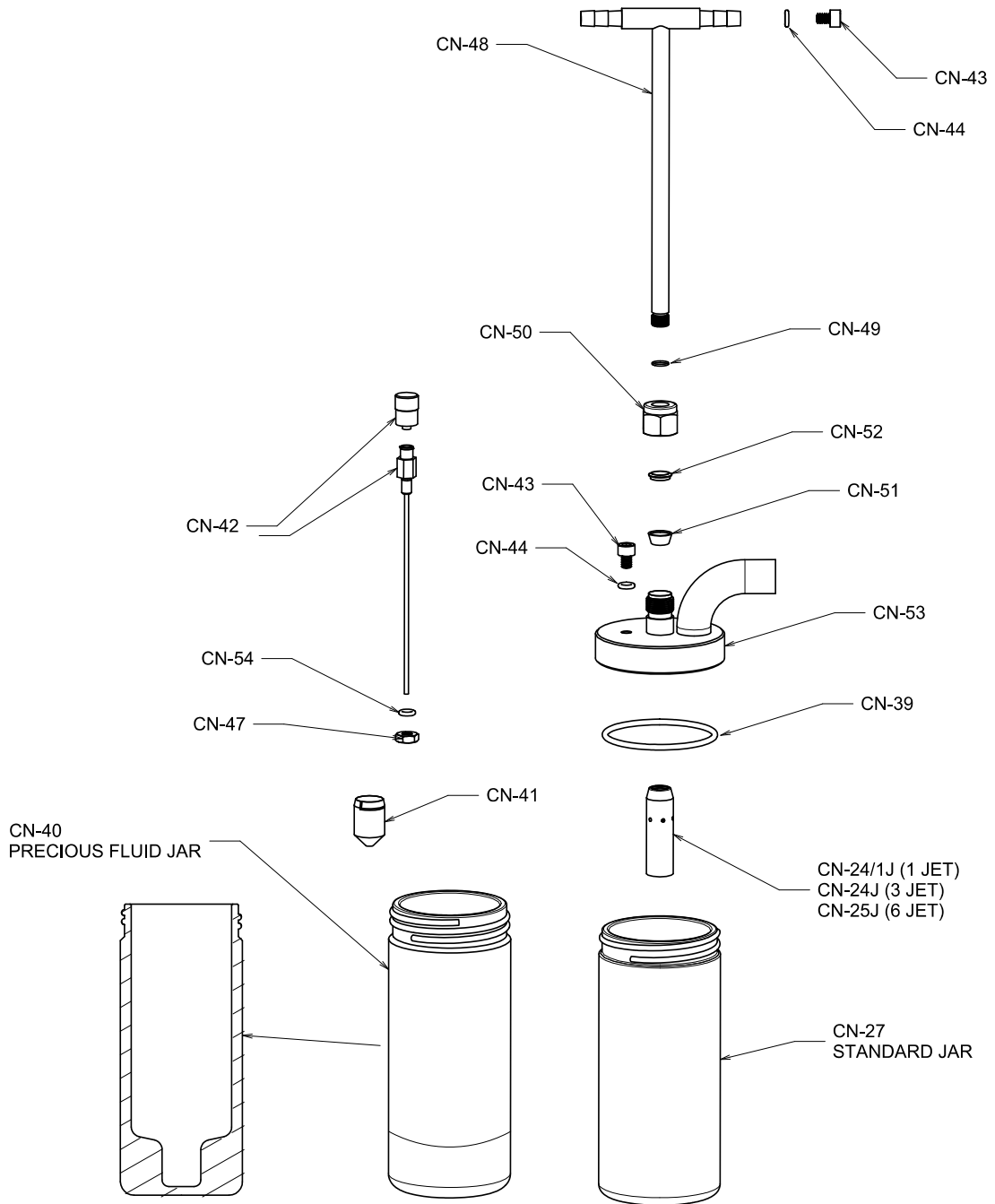
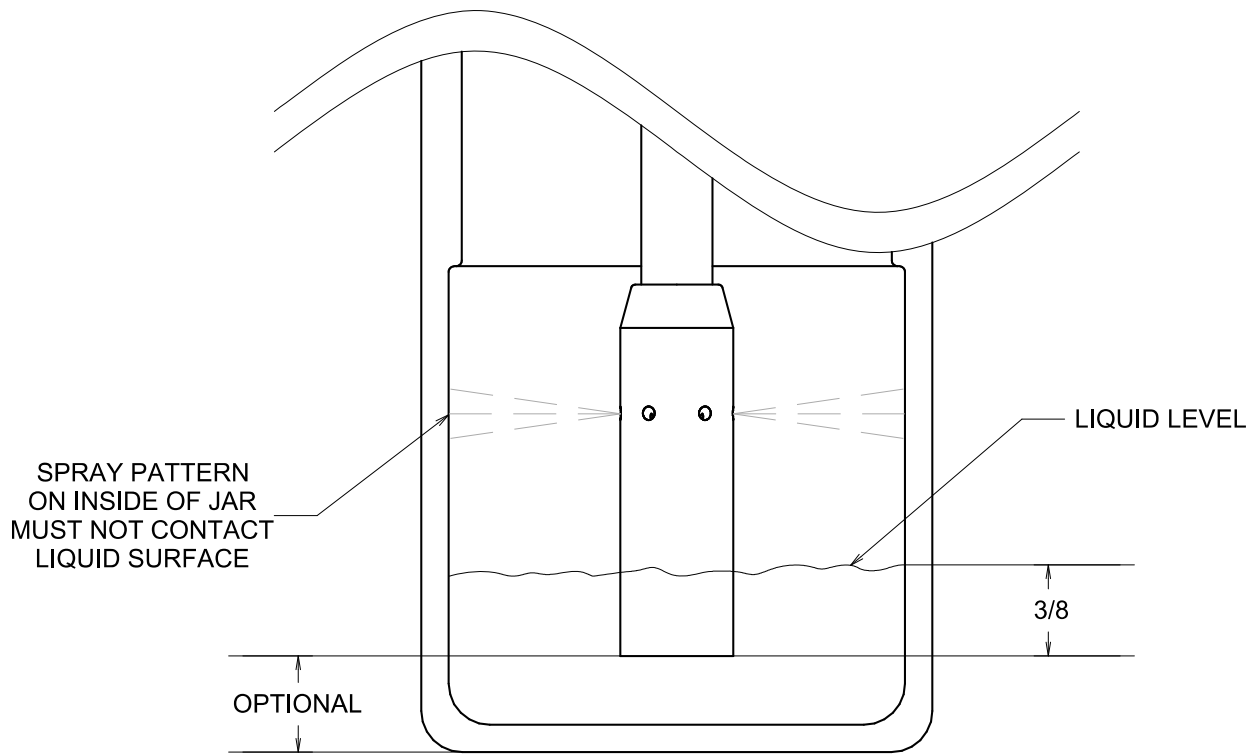

FIGURE 1. SCHEMATIC DIAGRAM OF COLLISON NEBULIZER



1747

FIGURE 2. EXPLODED VIEW OF COLLISION NEBULIZER



1745

FIGURE 3. SUBMERSION DEPTH OF NOZZLE TIP

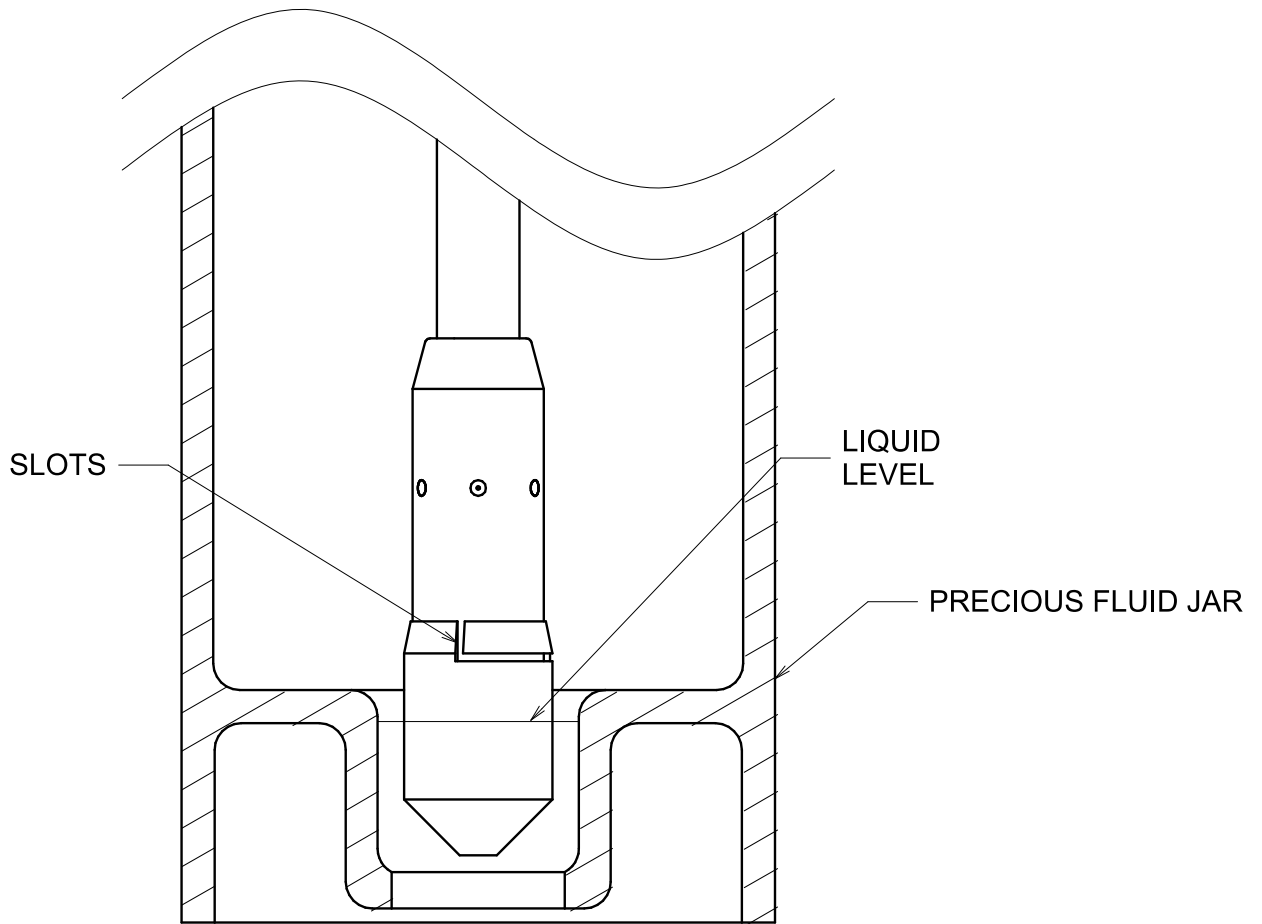

1744

FIGURE 4. VIEW OF CORRECT INSTALLATION OF  
PRECIOUS FLUIDS SLEEVE IN PRECIOUS FLUID JAR

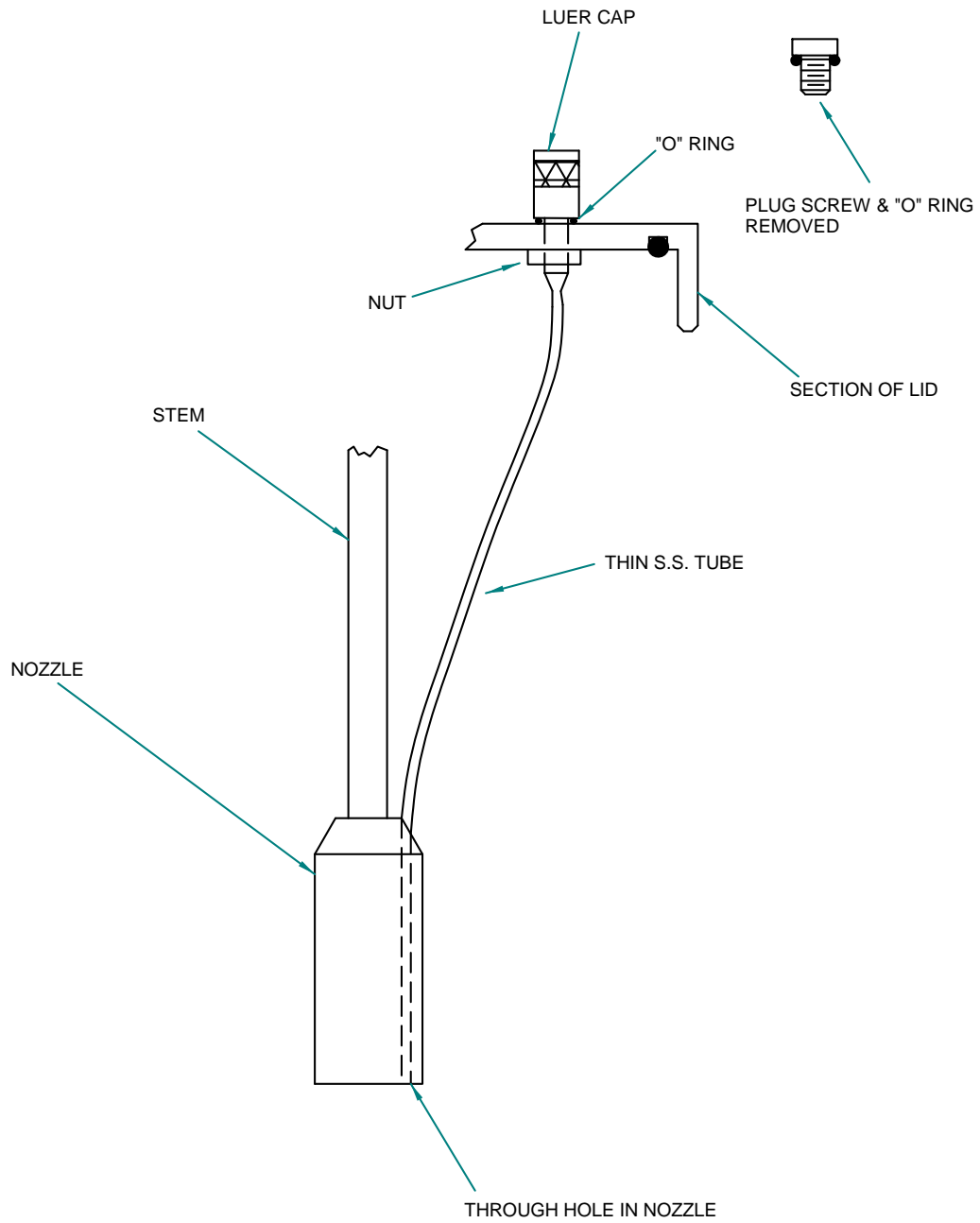

1743  
FIGURE 5. INSTALLATION OF EXTERNAL FILL ADAPTOR

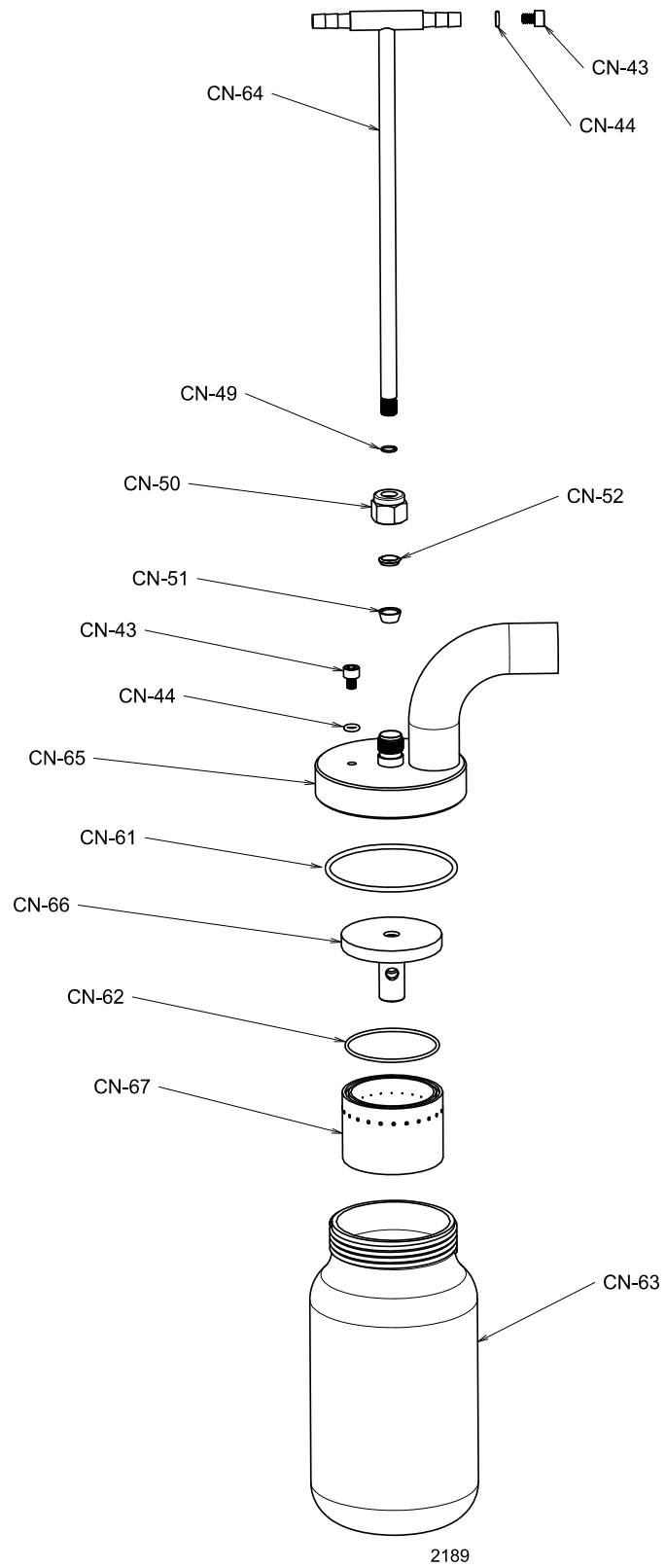

FIGURE 6. EXPLODED VIEW OF 24 JET COLLISON